

# Garage

ASSEMBLY INSTRUCTIONS

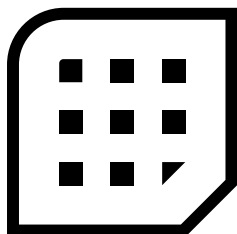

**modular  
closets.**

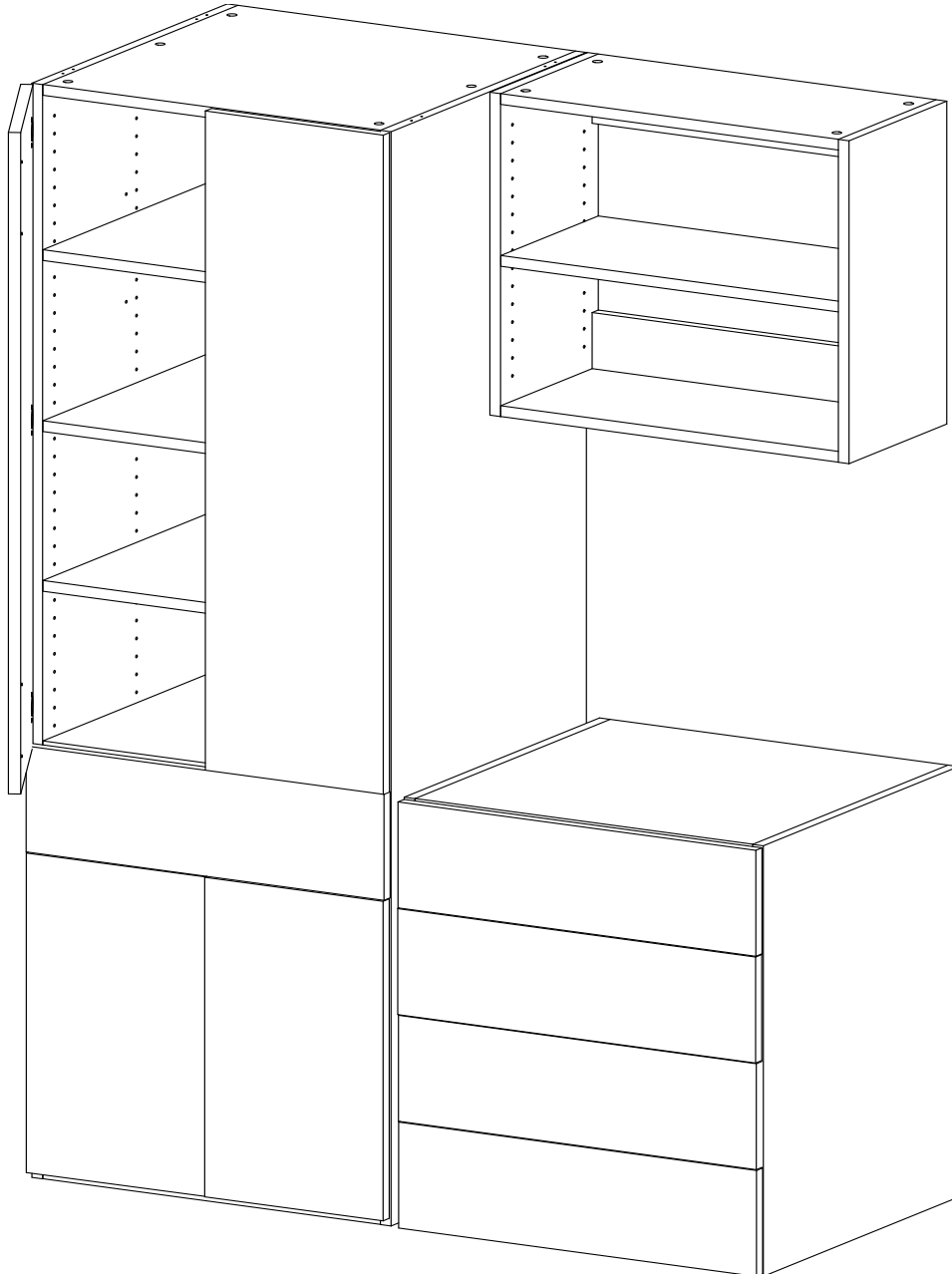

Congratulations on your purchase!

For any questions reach out to [support@modularclosets.com](mailto:support@modularclosets.com) or call 844-969-4247

**Thank you for choosing Modular Closets and our Garage system!**

We are committed to providing you with a seamless and efficient storage solution that enhances the organization and functionality of your space. Before you embark on assembling your new Garage system, we want to emphasize a crucial step to ensure a smooth and successful installation.

**Important: Understanding Your Components**

Before you begin the assembly process, it is essential to familiarize yourself with the components provided in your package. Our Garage system includes various boxes containing different parts designated for specific towers. Properly identifying and organizing these components will prevent confusion and streamline the installation.

**What You Need to Do**

- 1. Inventory Check:** Begin by unpacking all the boxes and verifying the contents against the parts list provided. Ensure that you have all the necessary components and hardware.
- 2. Label and Sort:** Carefully read the labels on each box and sort the components according to the designated towers. This step is critical as it will help you avoid mixing parts that belong to different sections of the closet system.
- 3. Check Sizes:** Verify the sizes of the components against the measurements specified in your design PDF. Ensuring that each part matches the intended dimensions is crucial for a proper fit and installation.
- 4. Reference Your Design PDF:** Use the design PDF provided with your order to map out the correct placement of each component. This document will guide you in matching the parts to their specific locations within the closet system.
- 5. Read the Instructions:** Thoroughly read through the entire instruction manual before starting the assembly. Understanding the overall process and the sequence of steps will save you time and effort.

By taking the time to carefully organize, understand your components, and reference your design PDF, you set the stage for a successful and stress-free installation. We are confident that with a little preparation, you will find the assembly process straightforward and rewarding.

Thank you for your attention to these important details.

**Now, let's get started on transforming your space with your new Garage closet system from Modular Closets!**

# Contents

Garage Base ..... 4  
Garage Wall ..... 19  
Garage Tall ..... 33

## APPENDIX

(A) Adjustable Shelves ..... 49  
(B) Door Kits ..... 58  
(C) Drawer Kits ..... 66

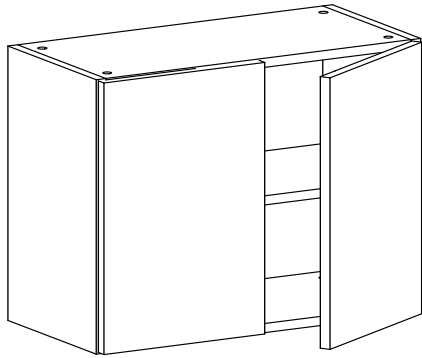

Wall

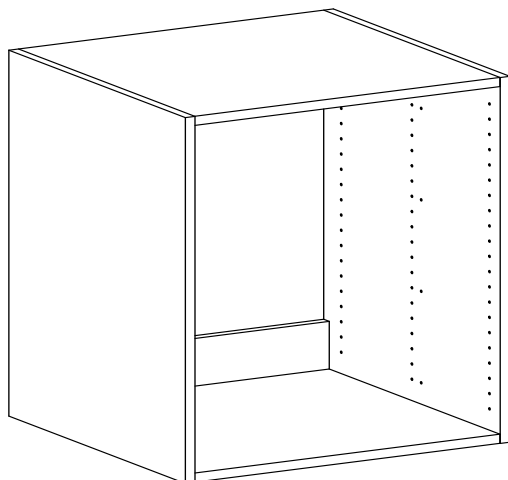

Base

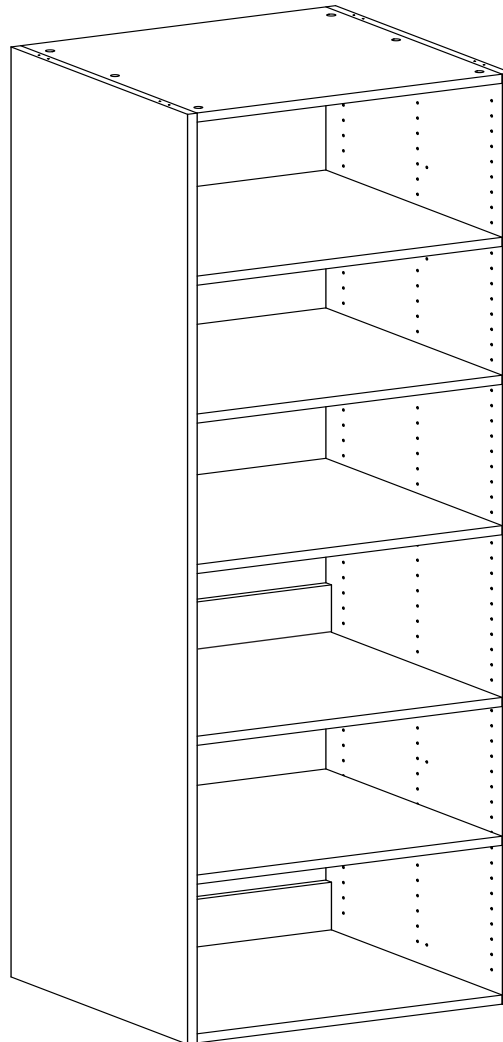

Tall



# Base Assembly

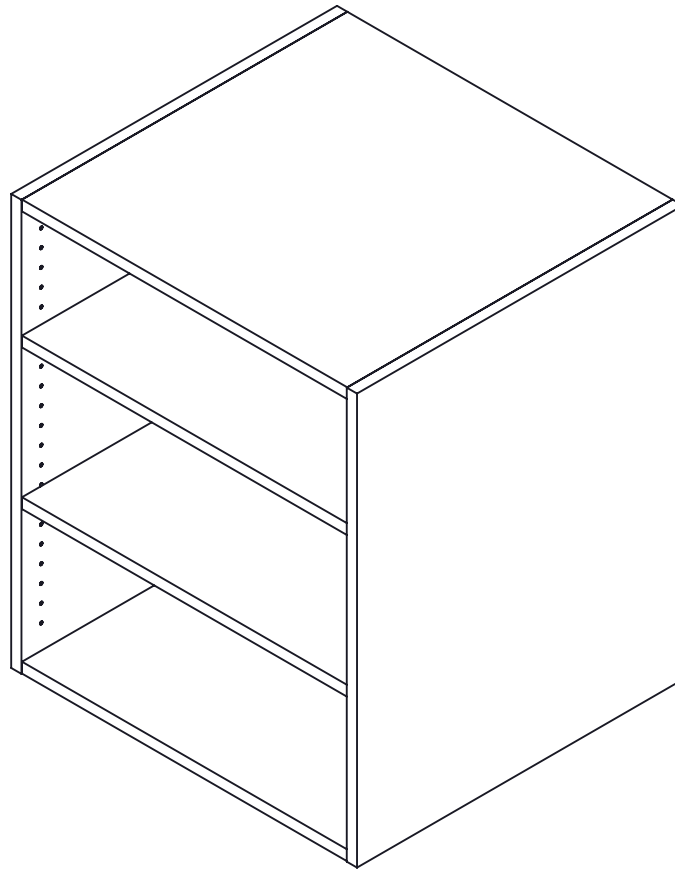

## Boxes Needed

GRG-BSP  
Base Side Panels

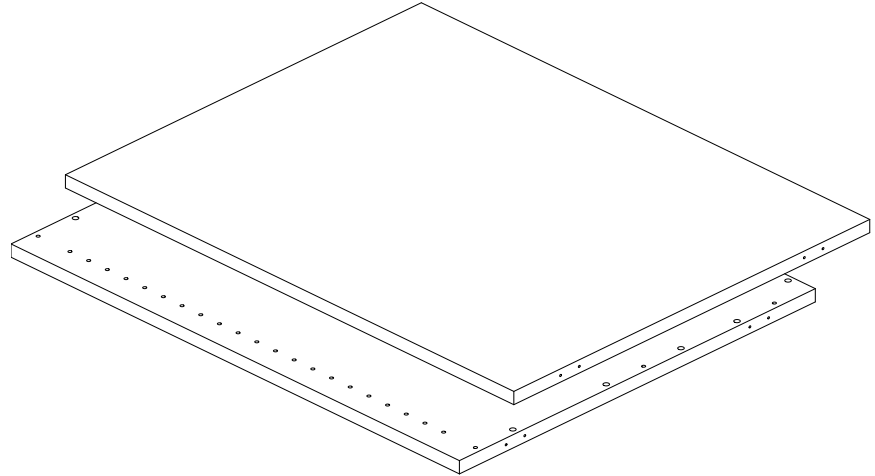

GRG-BFS  
Base Fixed Shelf Pack

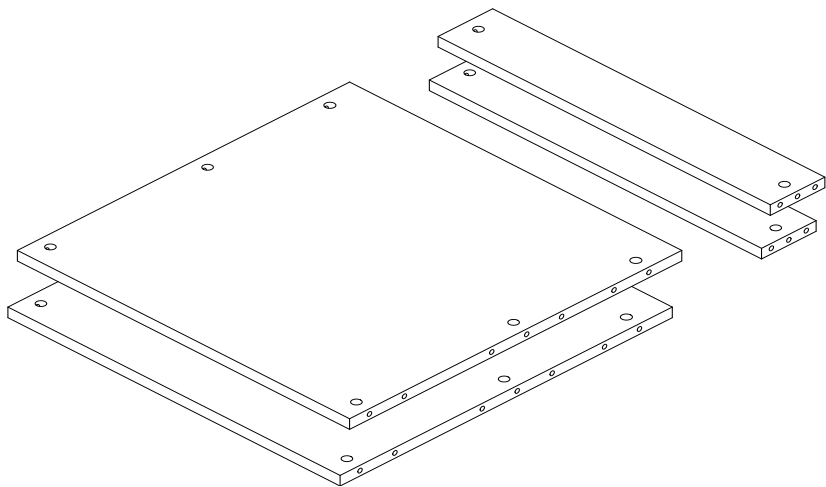

**Please hold additional boxes until after the base shell is completed. Afterwards all variants of the base unit will be listed. Please locate your variation for further instruction.**



Hardware Packs Needed  
GRG-HRDP-BFS

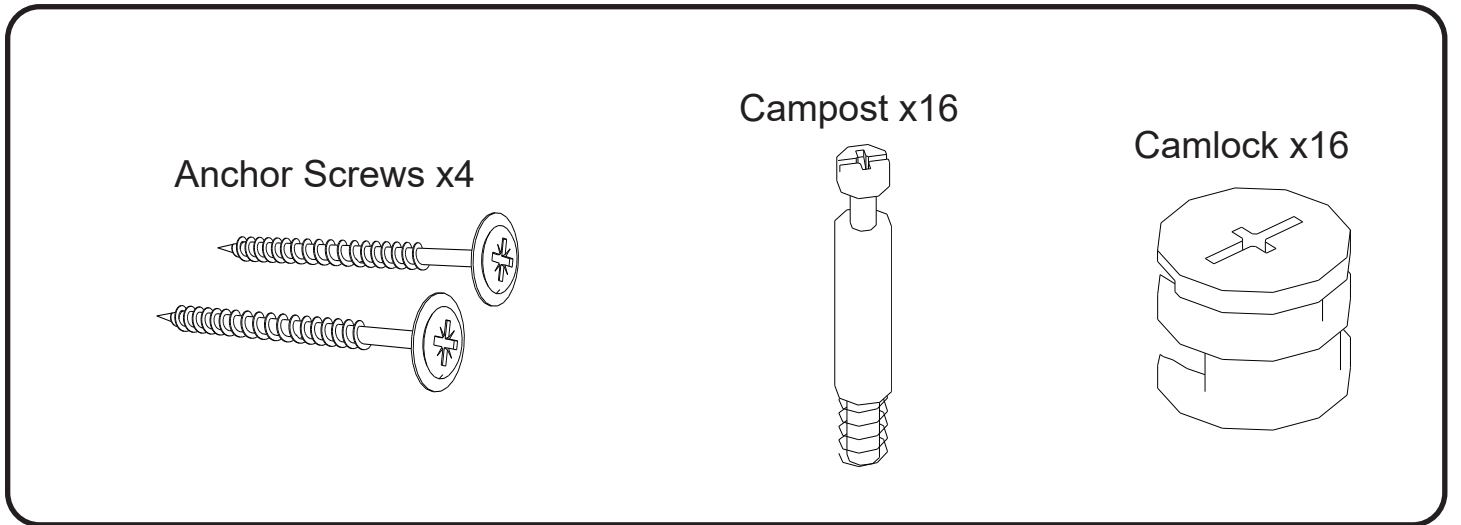

How to use the Cam lock system:

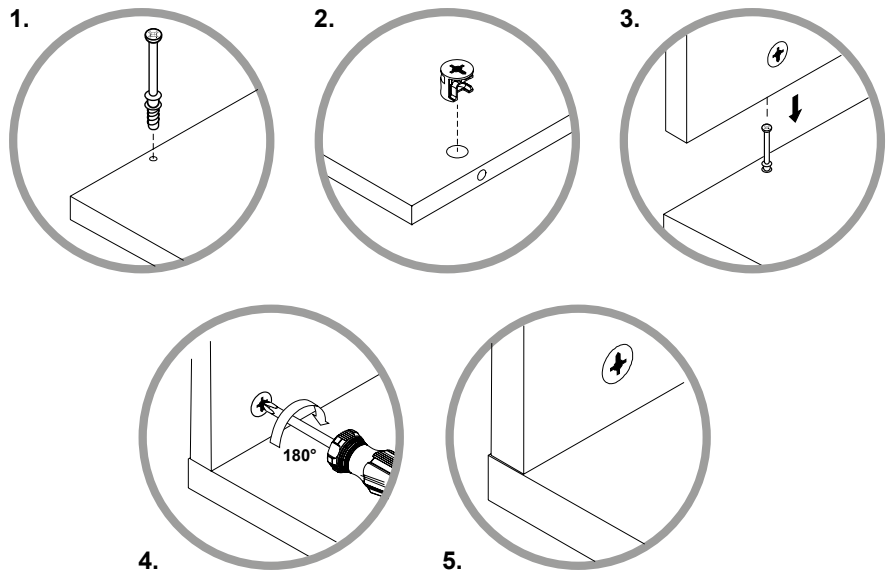

Tools needed

Rubber mallet



Drill

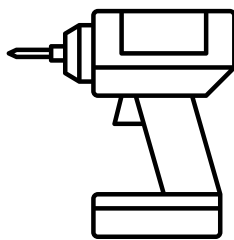

Level



Philips screw driver



Stud finder

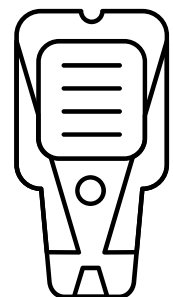

2 person assembly suggested

### Step 1

From Box GRG-BSP take the side panels and insert the hardware as shown and drill into place.

Campost

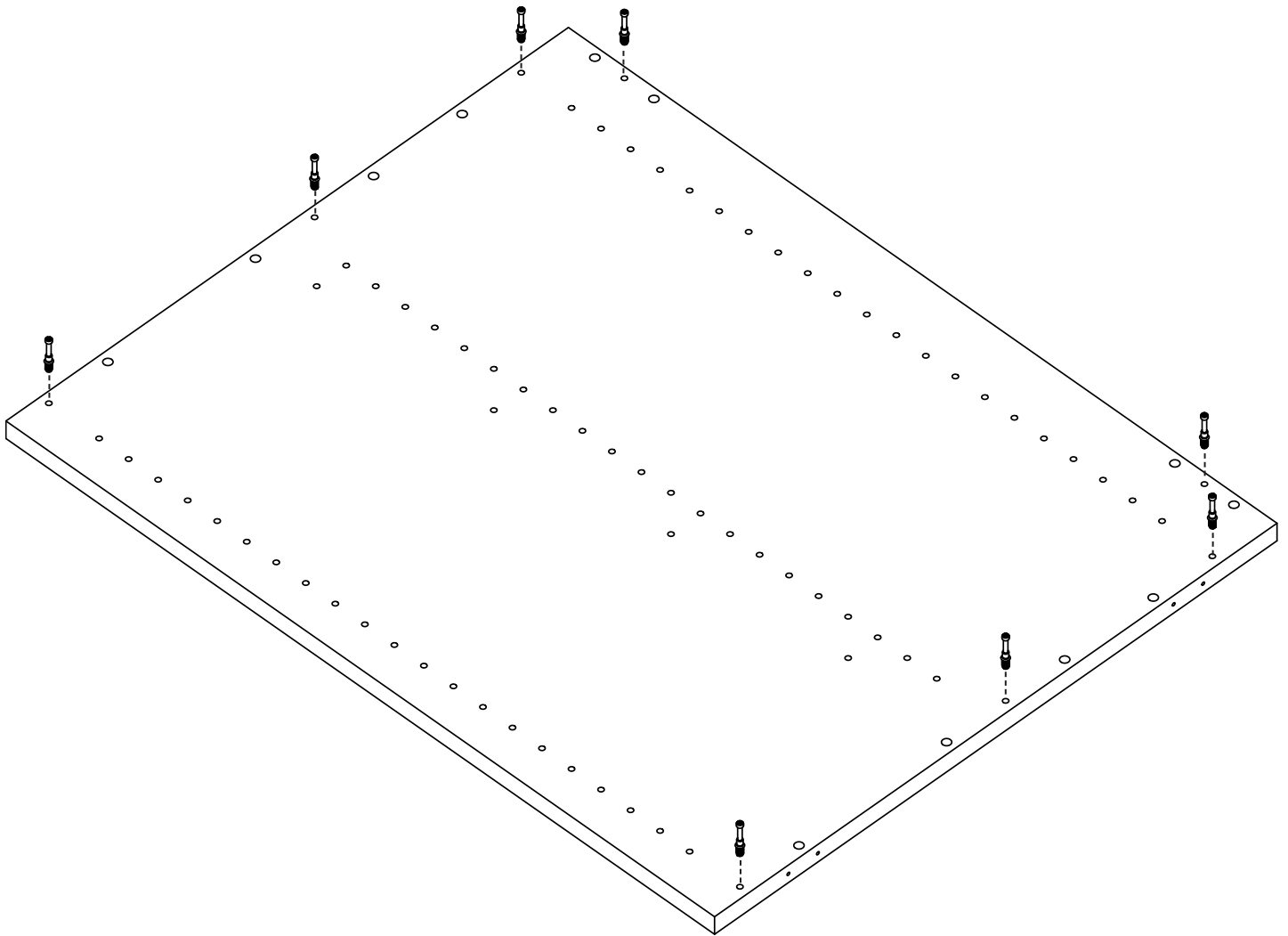



## Step 2

Repeat for other side panel.

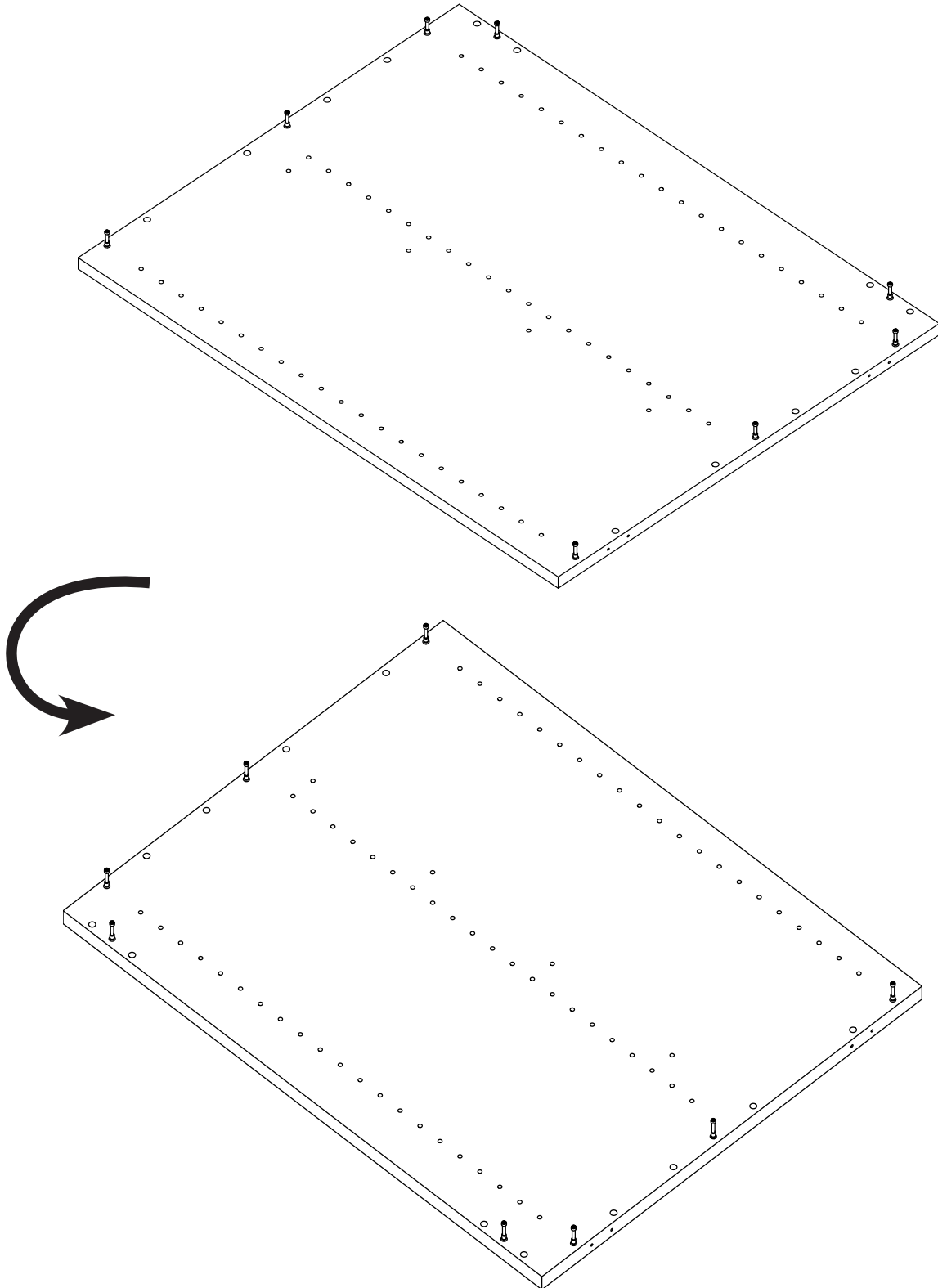



### Step 3

From the box GRG-BFS, insert camlocks in to the shelves and cleats, as shown below.

Camlock

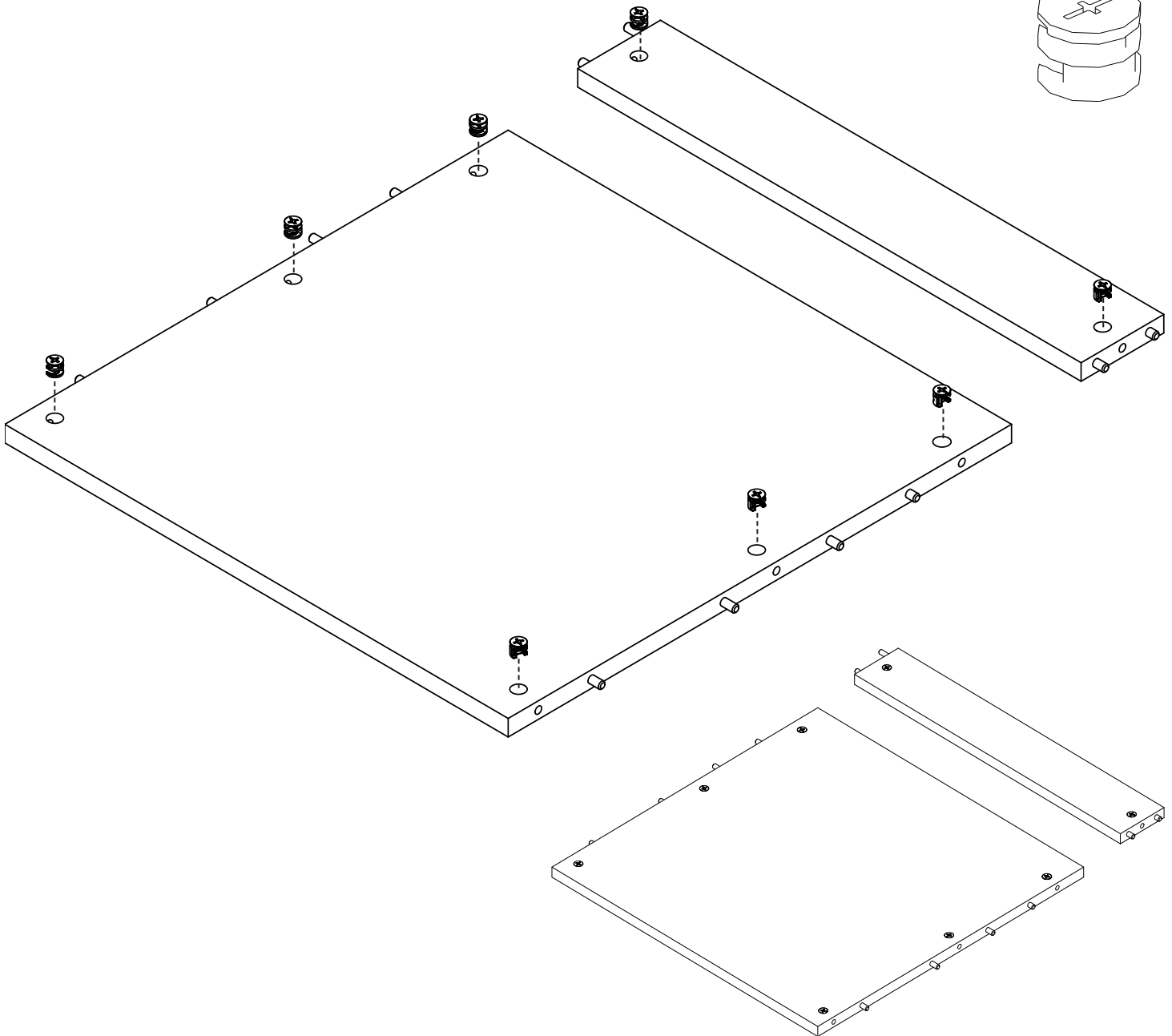
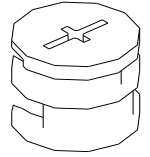

**Repeat Steps 2-3 for all the Fixed Shelves and Cleats**



### Step 4

With side panel flat insert fixed shelf and cleat into the panel.

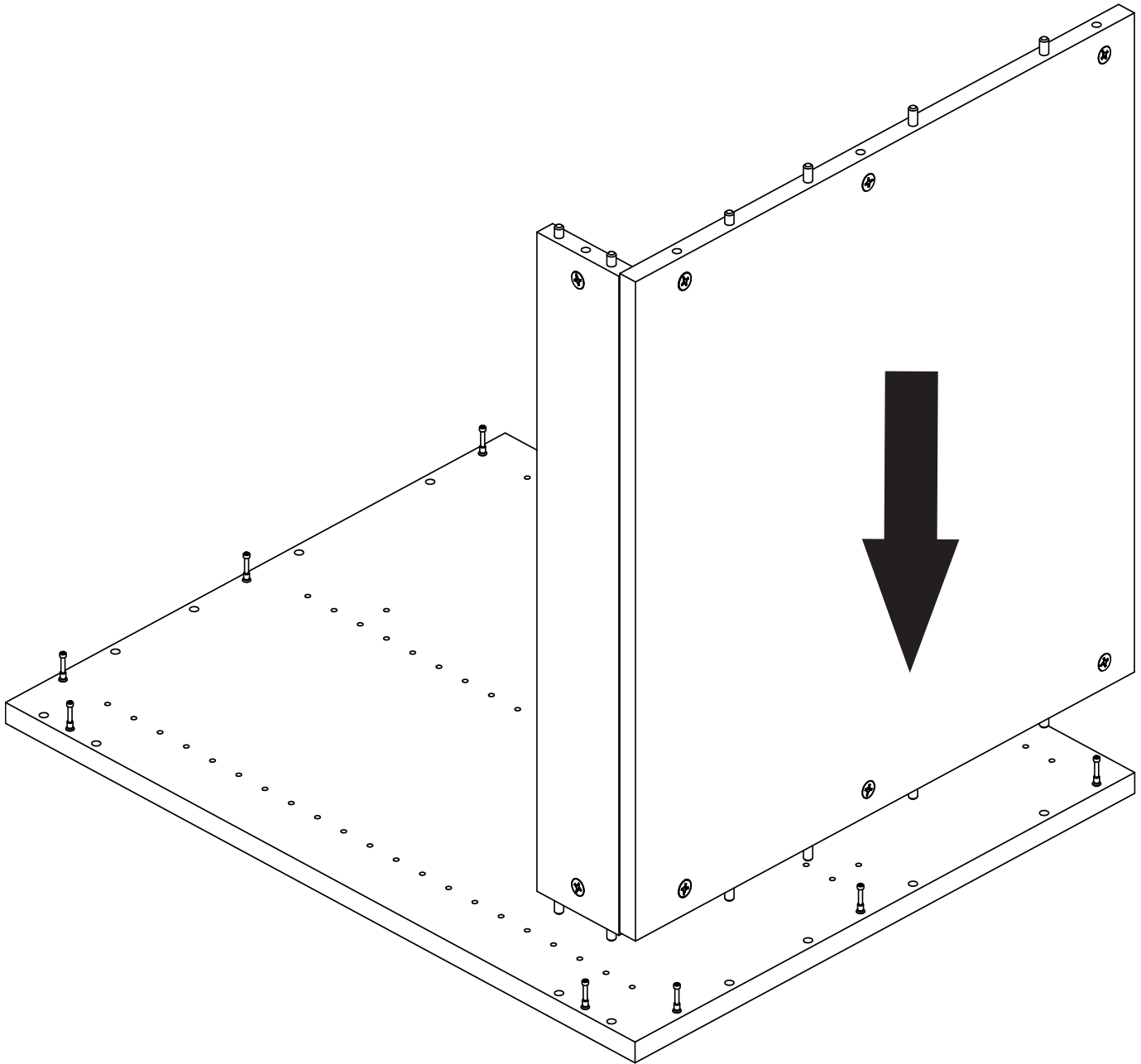

## Step 5

Tighten camlocks on the inserted shelf and cleat with screwdriver. For base units all camlocks on both fixed shelves should be pointed toward the floor.

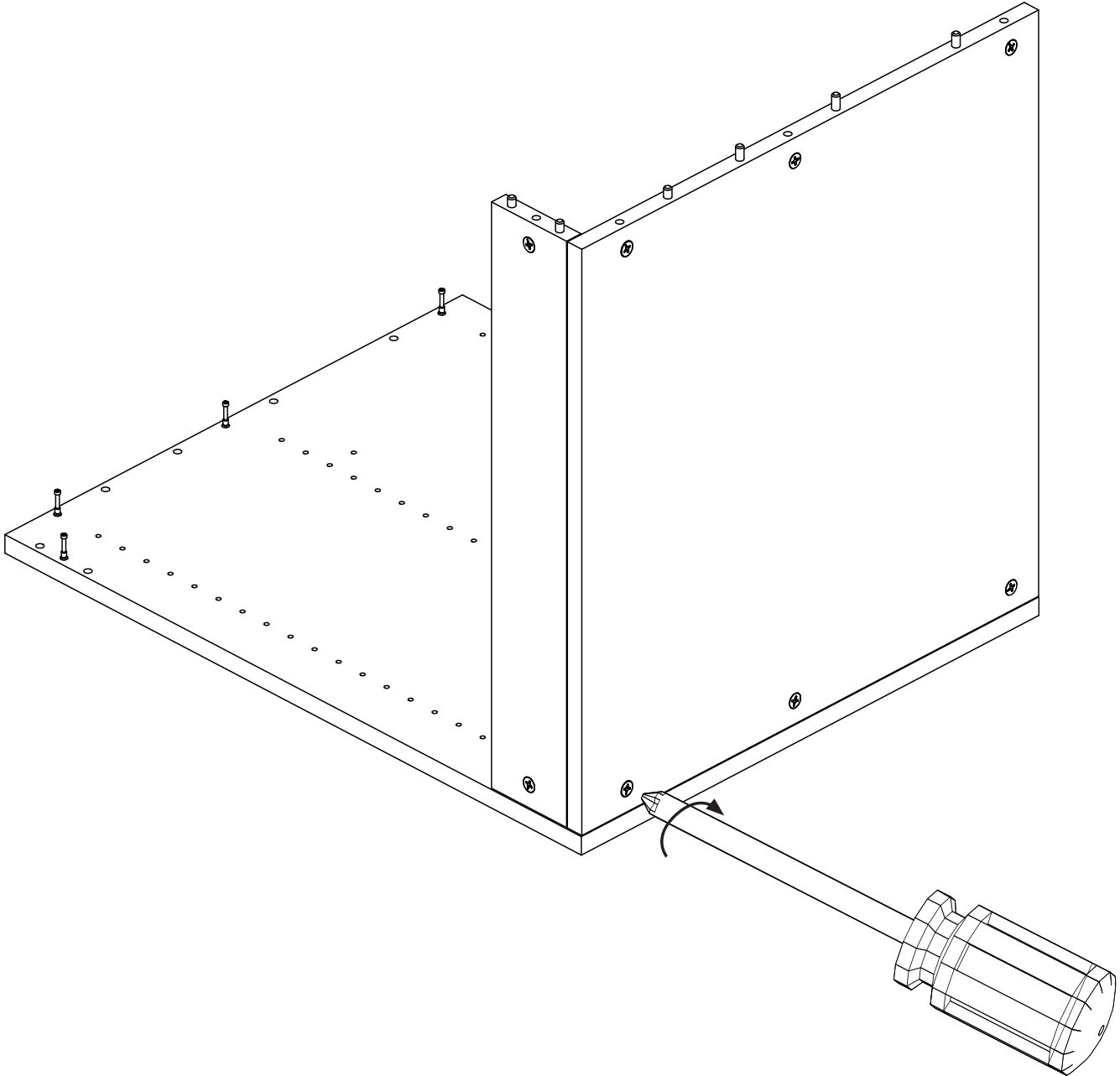



### Step 6

Insert additional fixed shelf and cleat on opposite side. Tighten camlocks.

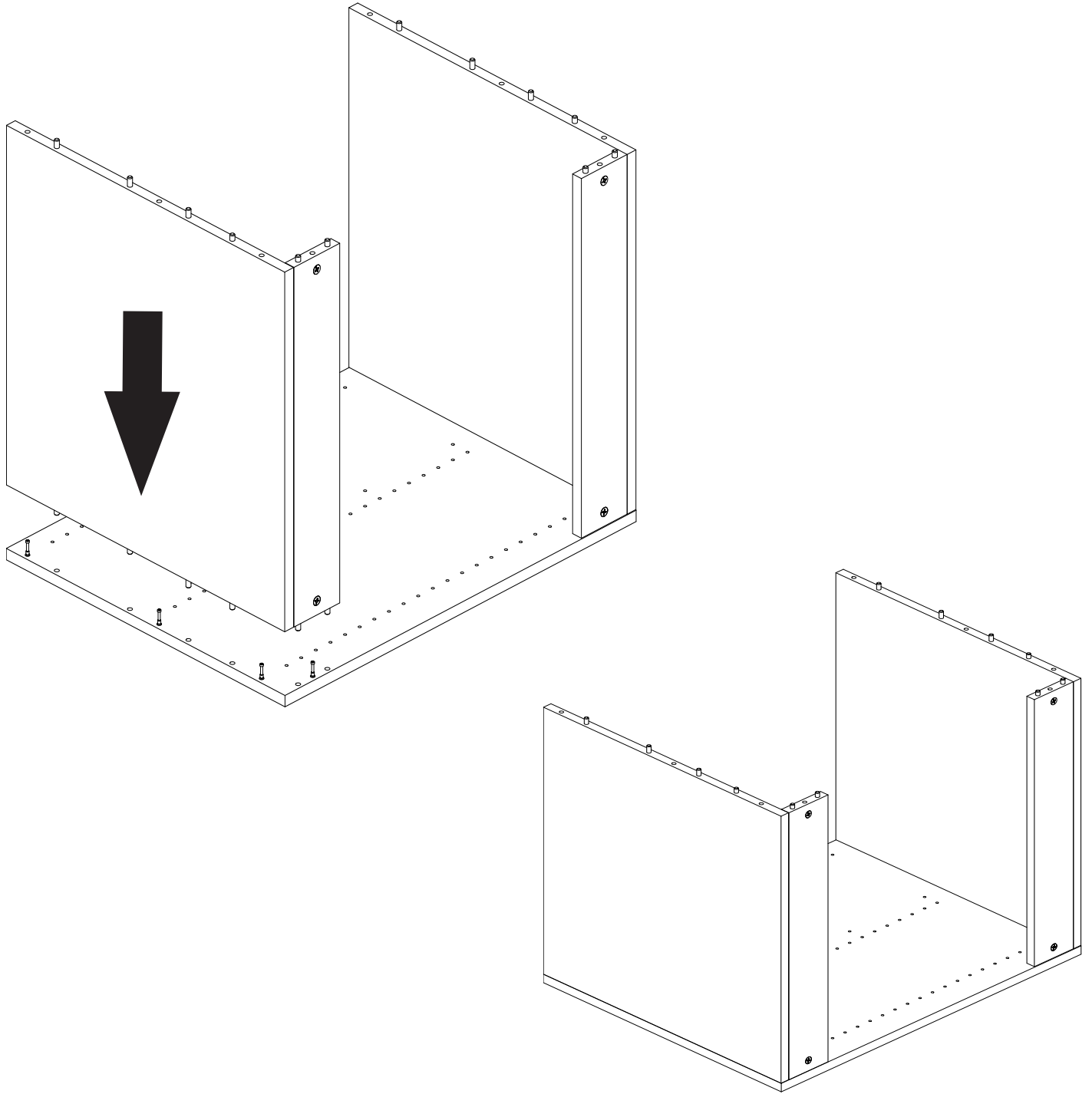

## Step 7

Insert side panel onto opposite side of installed fixed shelves and cleats.

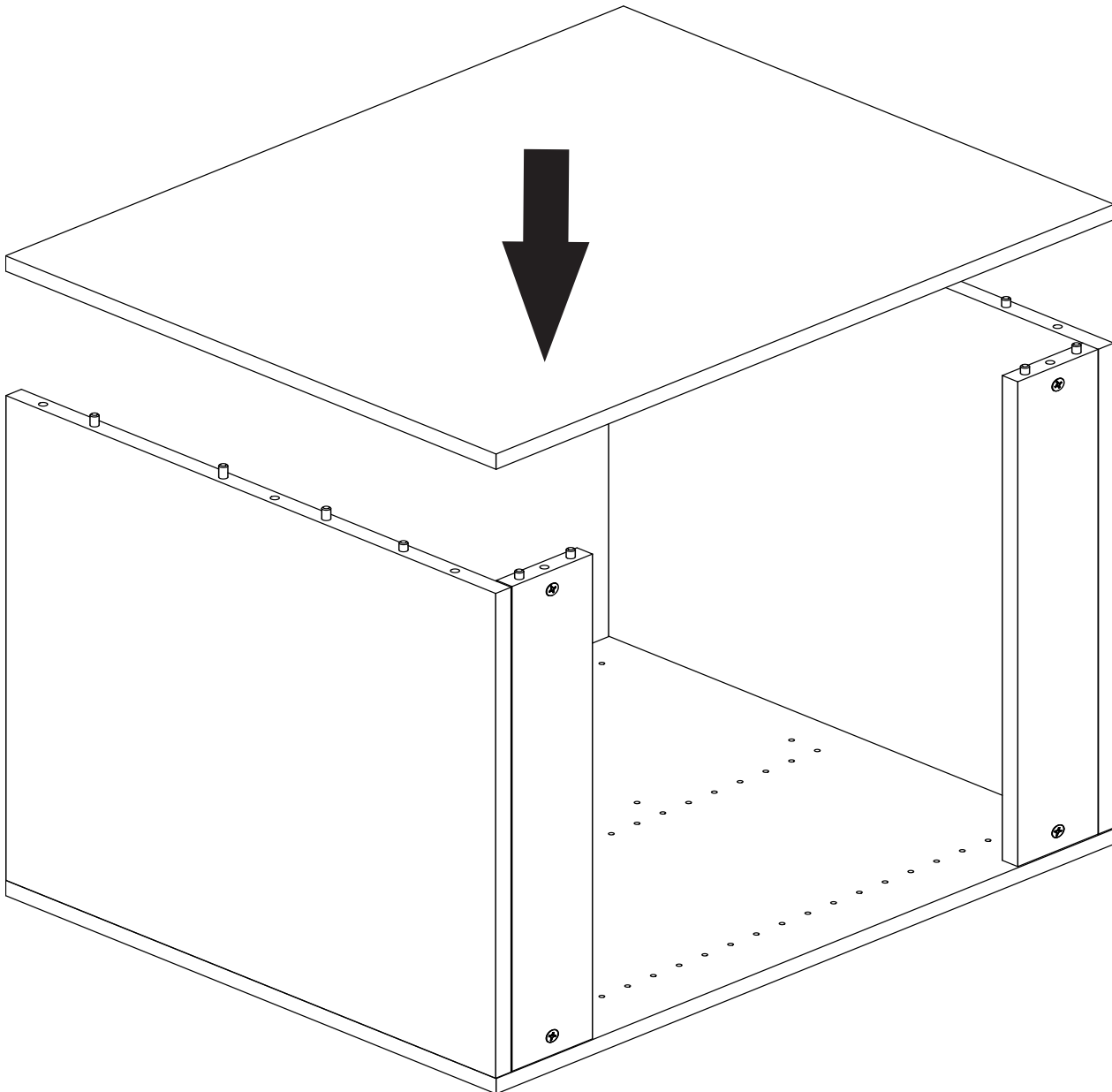



### Step 8

Tighten all camlocks connecting the attached side panel.

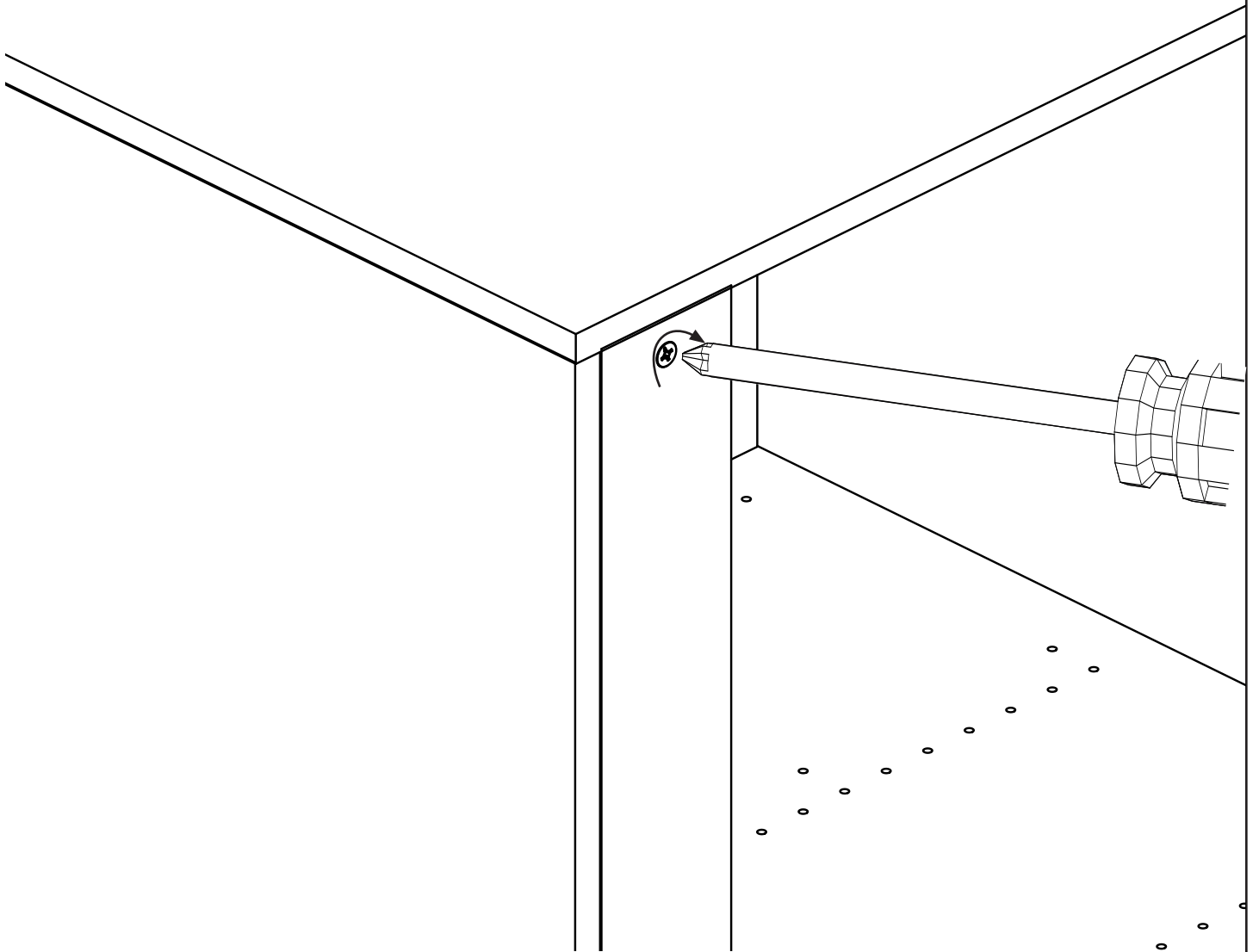

## Step 9

You have finished the base unit shell.

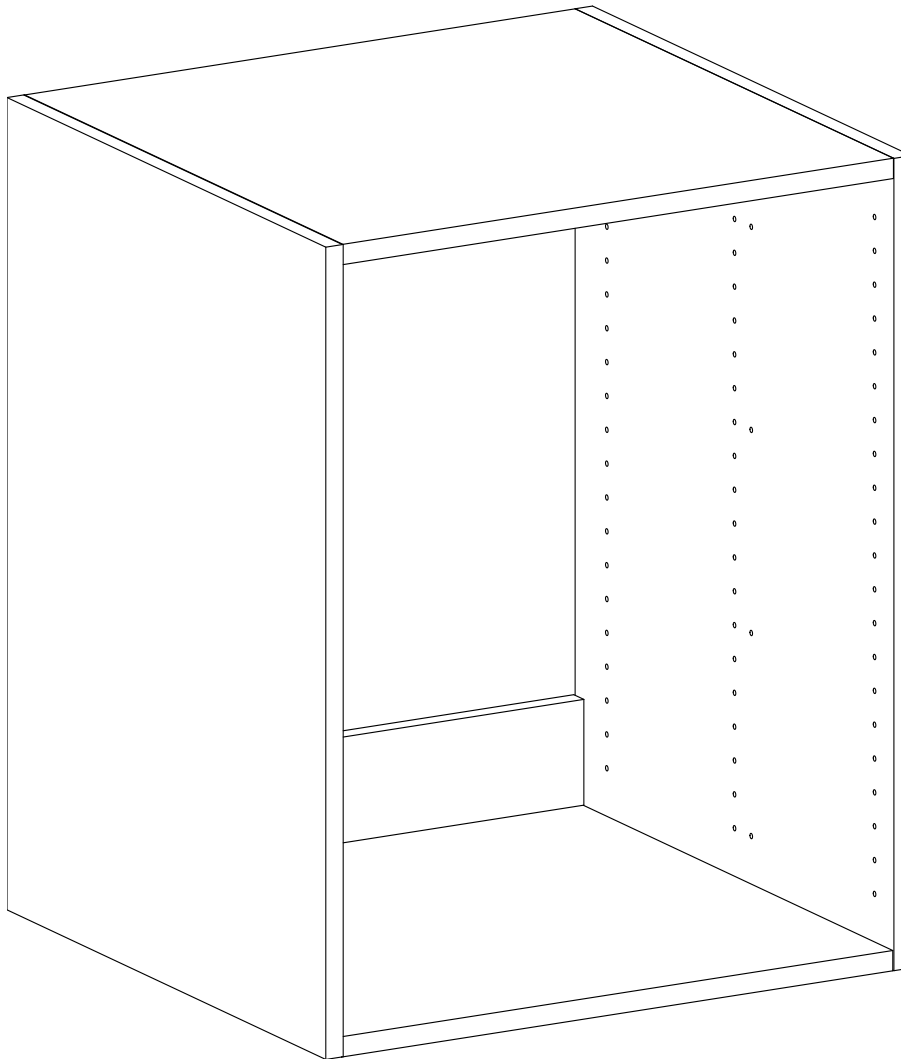



### Step 10

Open leg hardware pack (HRD-552). Lay each unit down carefully and use the pre-drilled pilot holes on the bottom of each side panel to align your legs correctly and drill them into place. Repeat as necessary.

Leg Kit

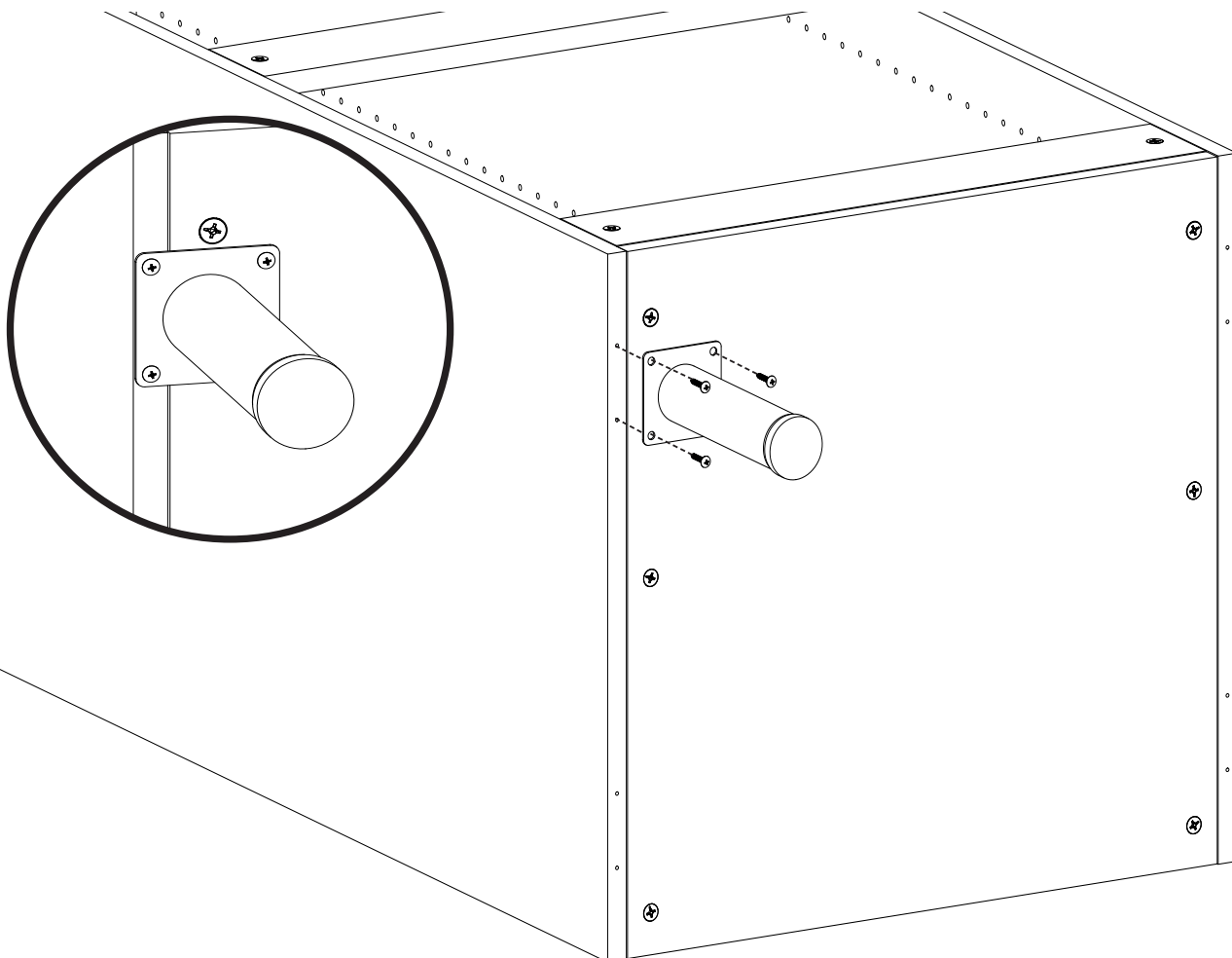
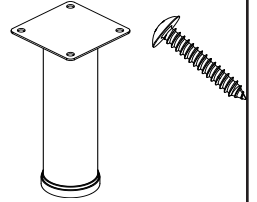



### Step 11

Using a stud finder, search for the studs in the wall and drill the screws through the top and bottom cleats in each unit into the studs. If there is only one stud, drill two screws into each cleat, one on top of the other.

anchor screws

x4

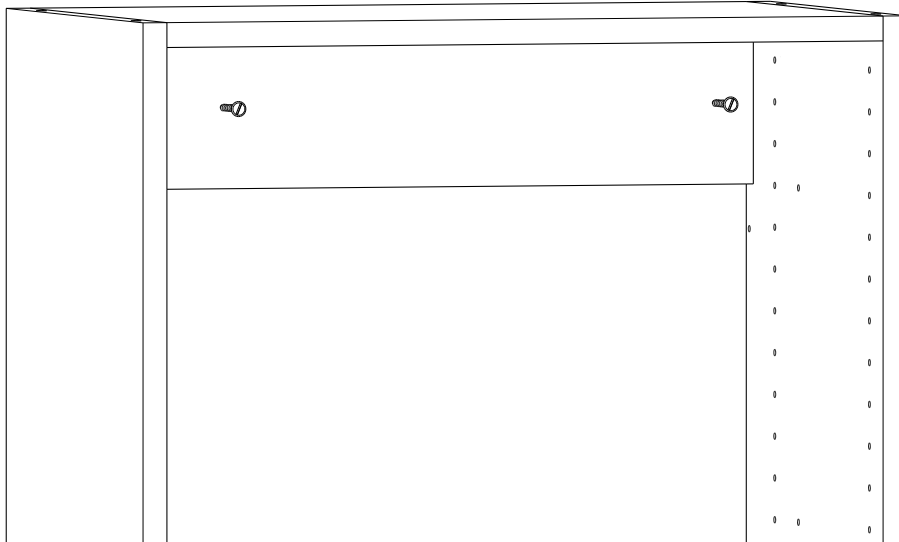
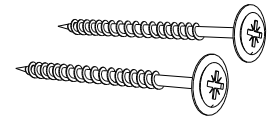



# Base Variants

Following completion of the base unit's shell you may now continue to whichever variant you are building from the styles shown below. Adjustable Shelves, Doors and Drawers instructions will be found in the appendix of this booklet.

## APPENDIX

(A) Adjustable Shelves .....	49
(B) Door Kits .....	58
(C) Drawer Kits .....	66

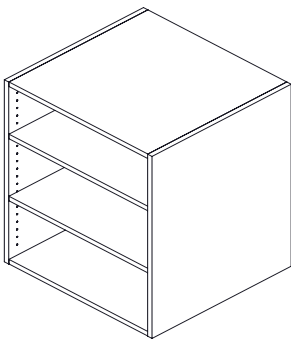

Adj. Shelves

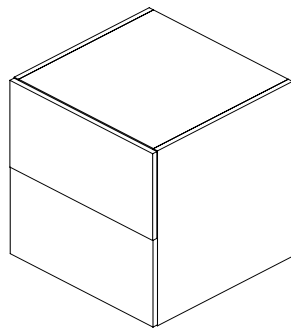

2 Drawers

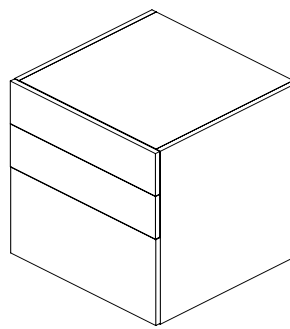

3 Drawers

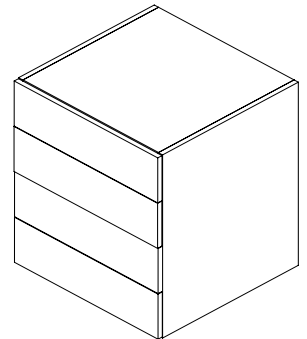

4 Drawers

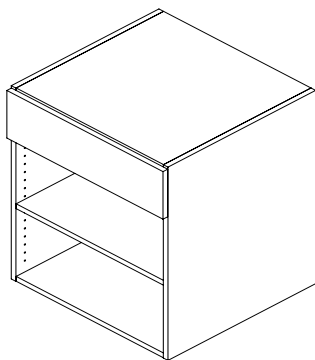

1 Drawer

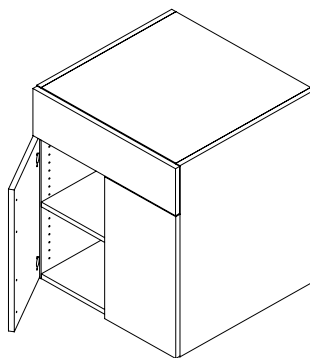

Doors  
1 Drawer

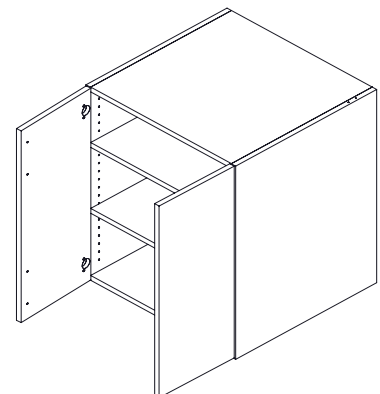

Doors

# Wall Assembly

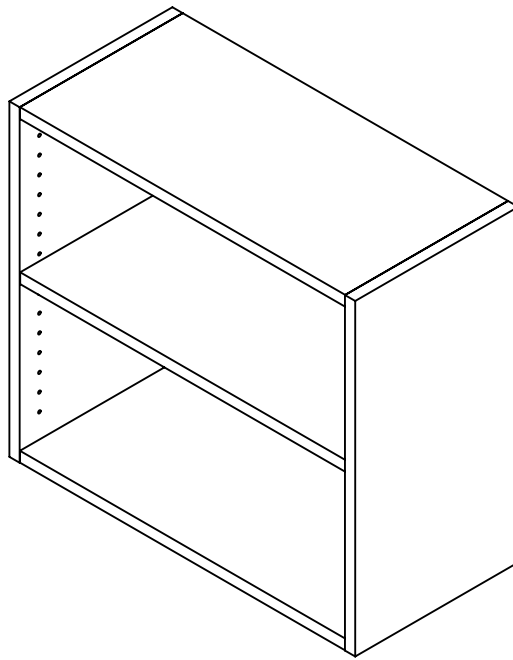



### Boxes Needed

GRG-WSP

Wall Side Panels

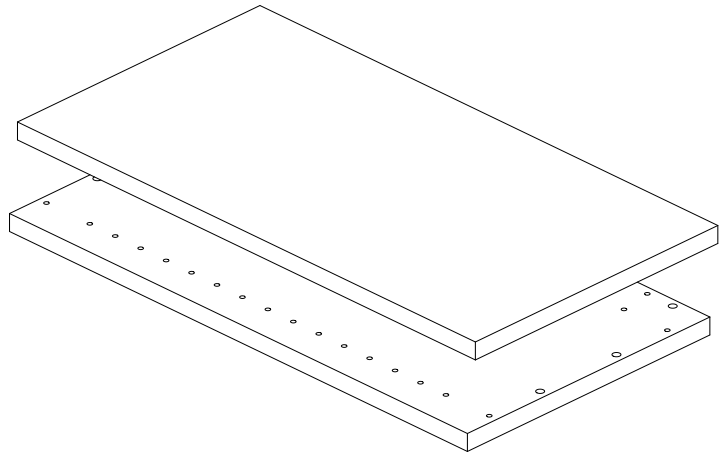

GRG-WFS

Wall Fixed Shelf Pack

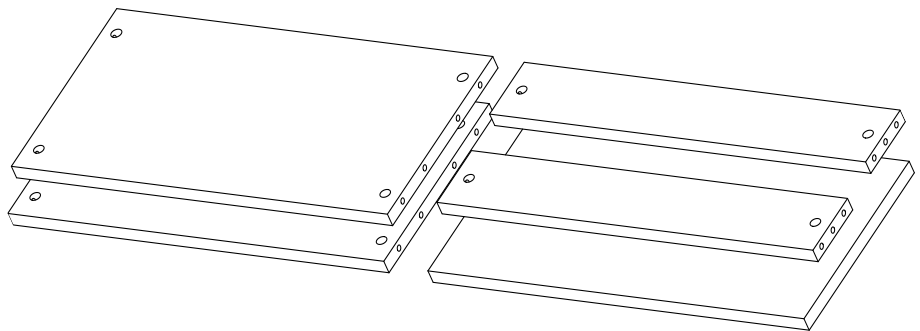

**Please set aside one shelf and additional boxes (doors) until after the wall shell is completed. Unused hardware (wedgefix and screw dowels) should be set aside for further use later on. Door and adjustable shelf instructions are located in the appendix. See table of contents on page 3.**

Hardware Packs Needed  
GRG-HRDP-WFS

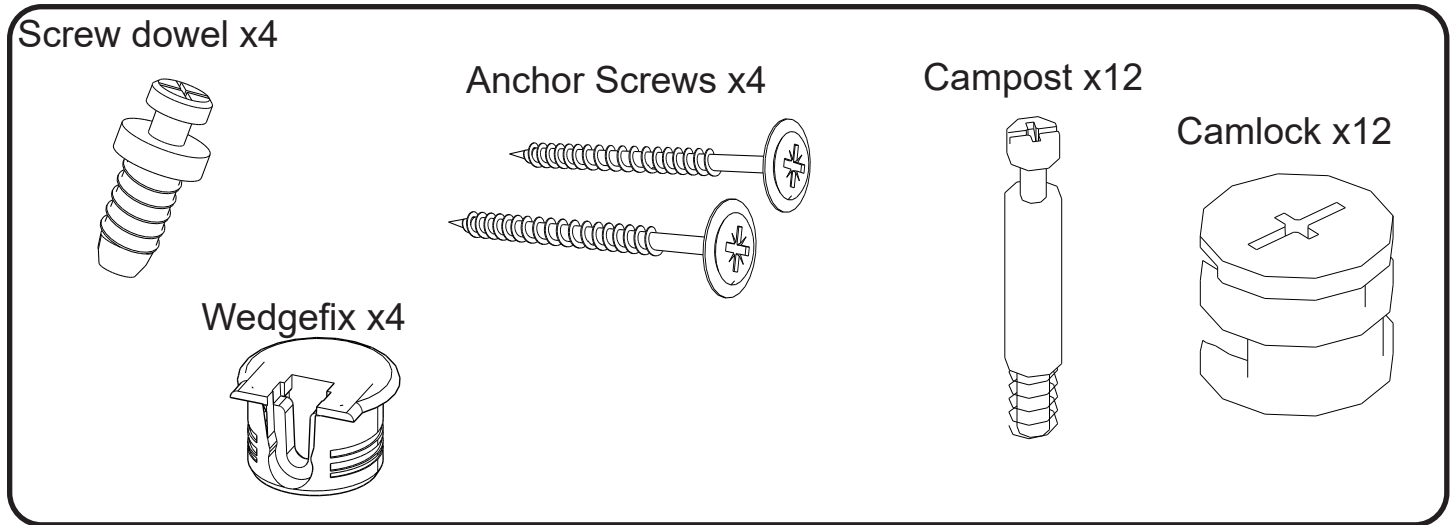

How to use the Cam lock system:

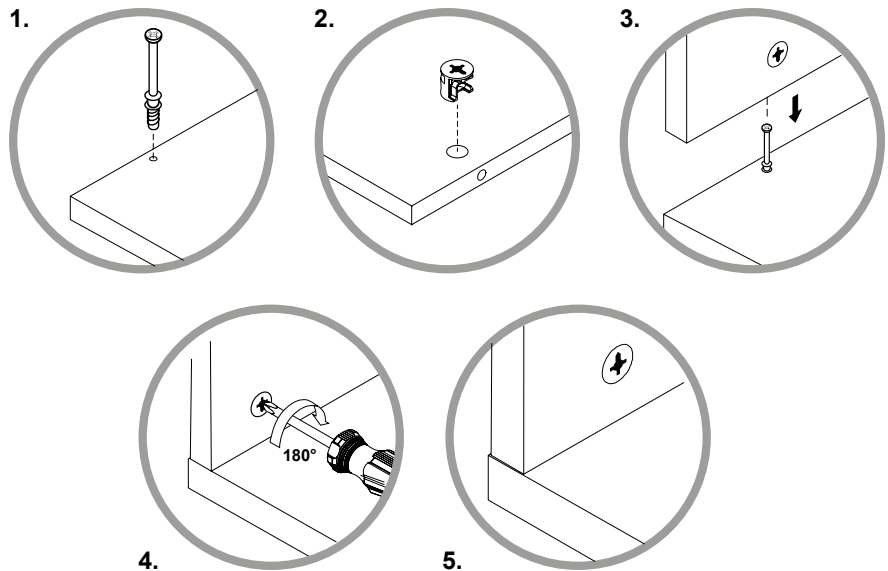

Tools needed

Rubber mallet



Drill

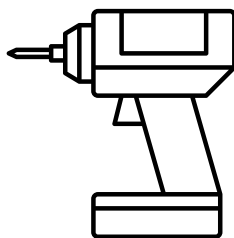

Level



Philips screw driver



Stud finder

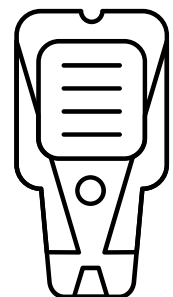

2 person assembly suggested



### Step 1

From Box GRG-WSP take the wall side panels and insert the hardware as shown and drill into place.

Campost

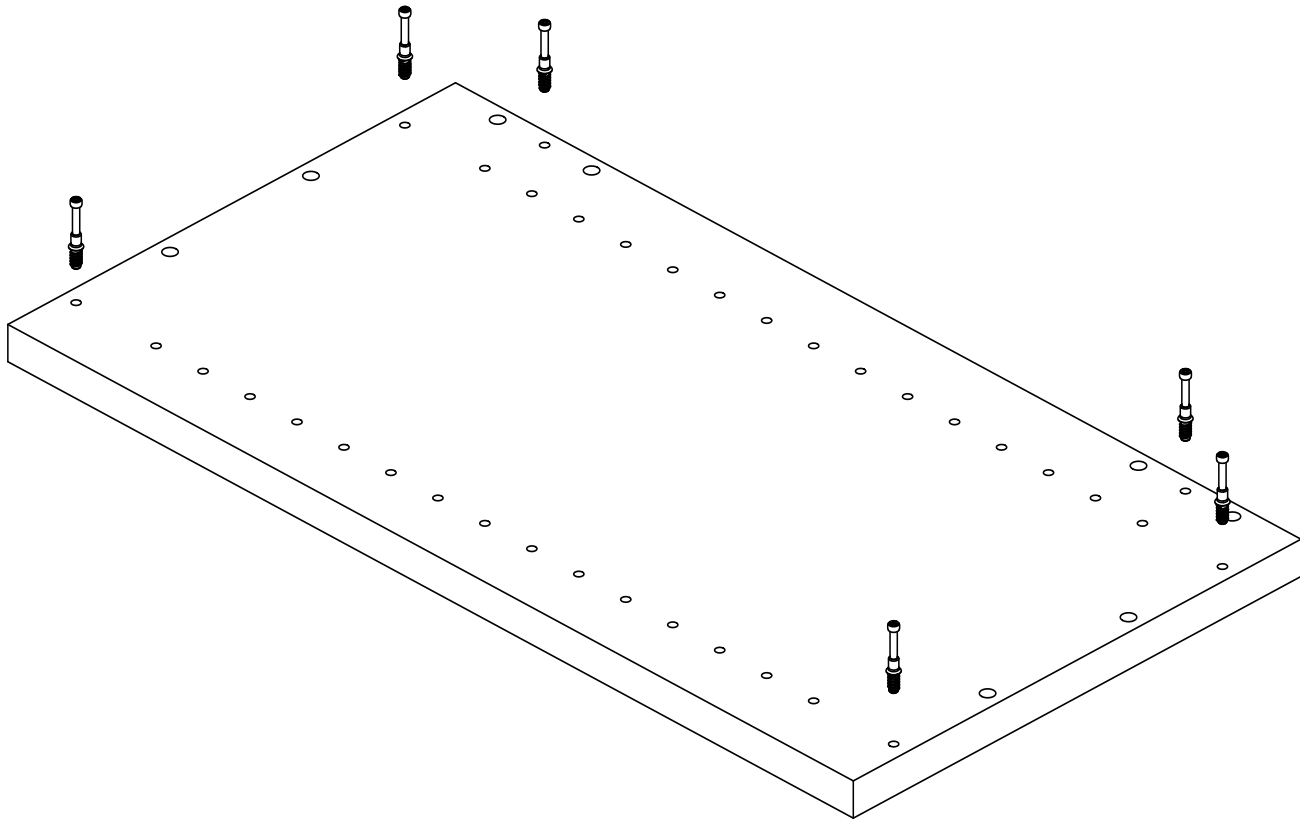

## Step 2

Repeat for other side panel.

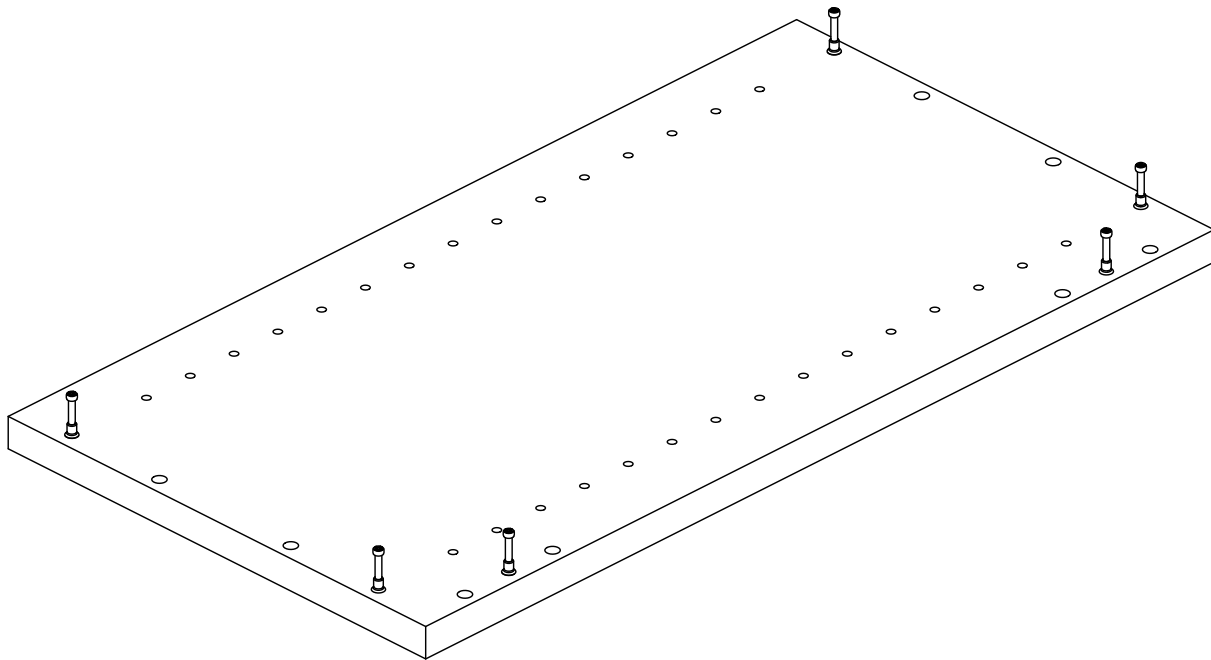
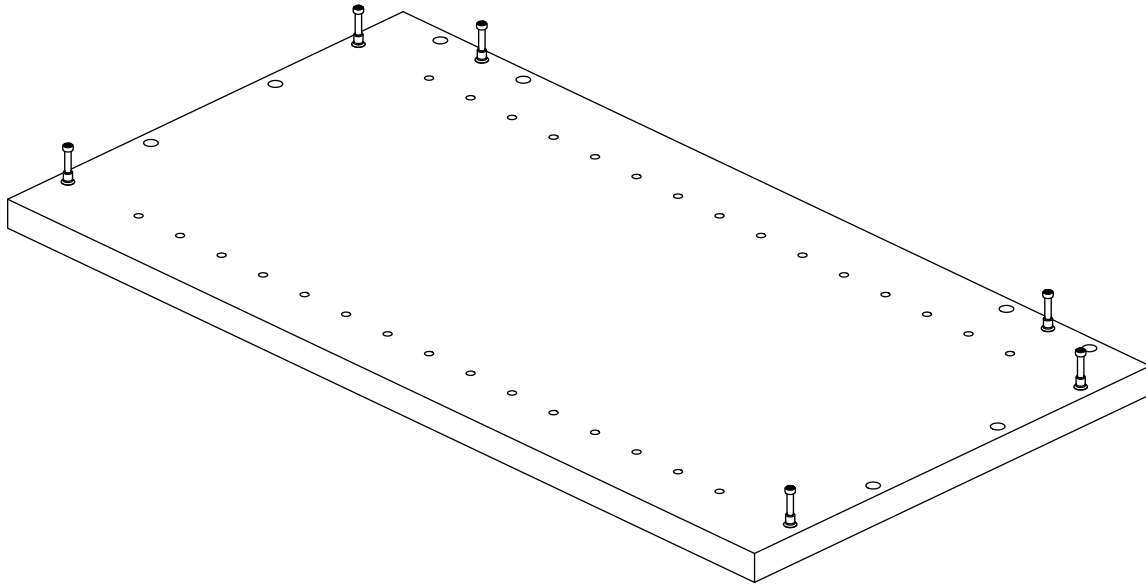



### Step 3

Insert campost hardware into fixed shelves and cleats from box GRG-WFS. Wall fixed shelf packs come with one adjustable. Set aside and view adjustable shelf instructions later.

Camlock

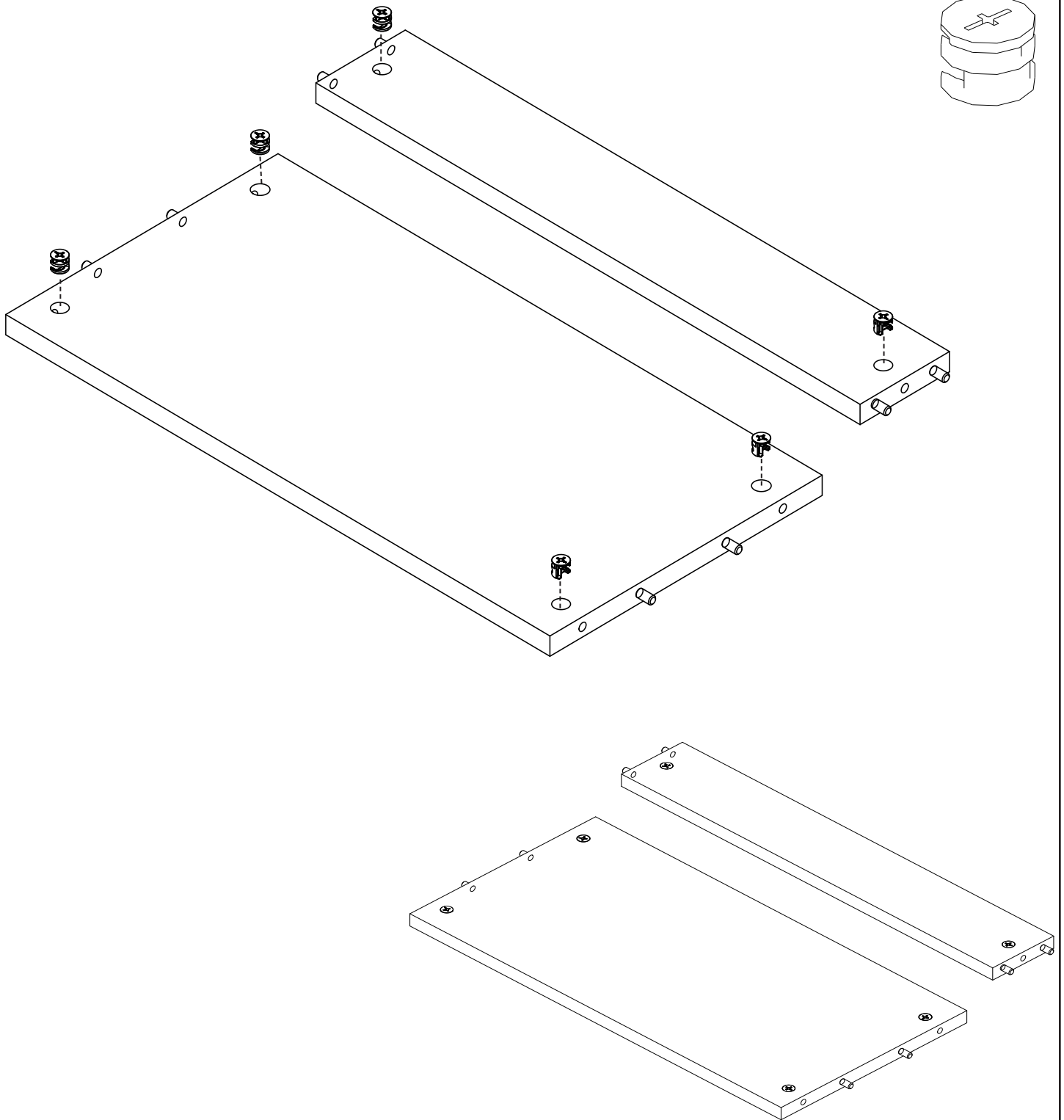
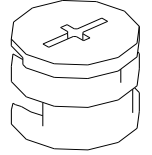



**Step 4**

Insert cleat and fixed shelf into side panel. Wall units have all camlocks facing away from the inside.

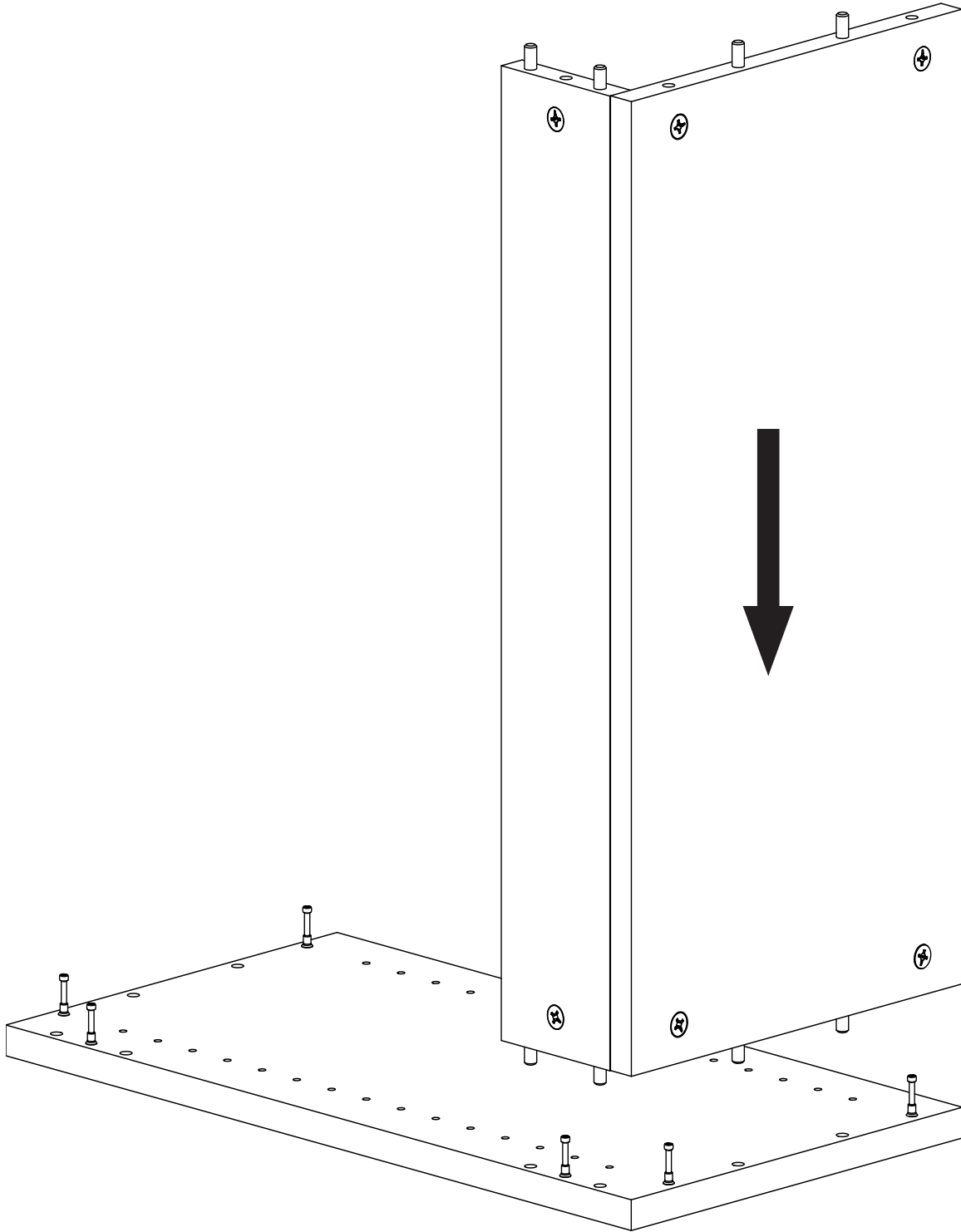



### Step 5

Tighten camlocks of attached shelf and cleat.

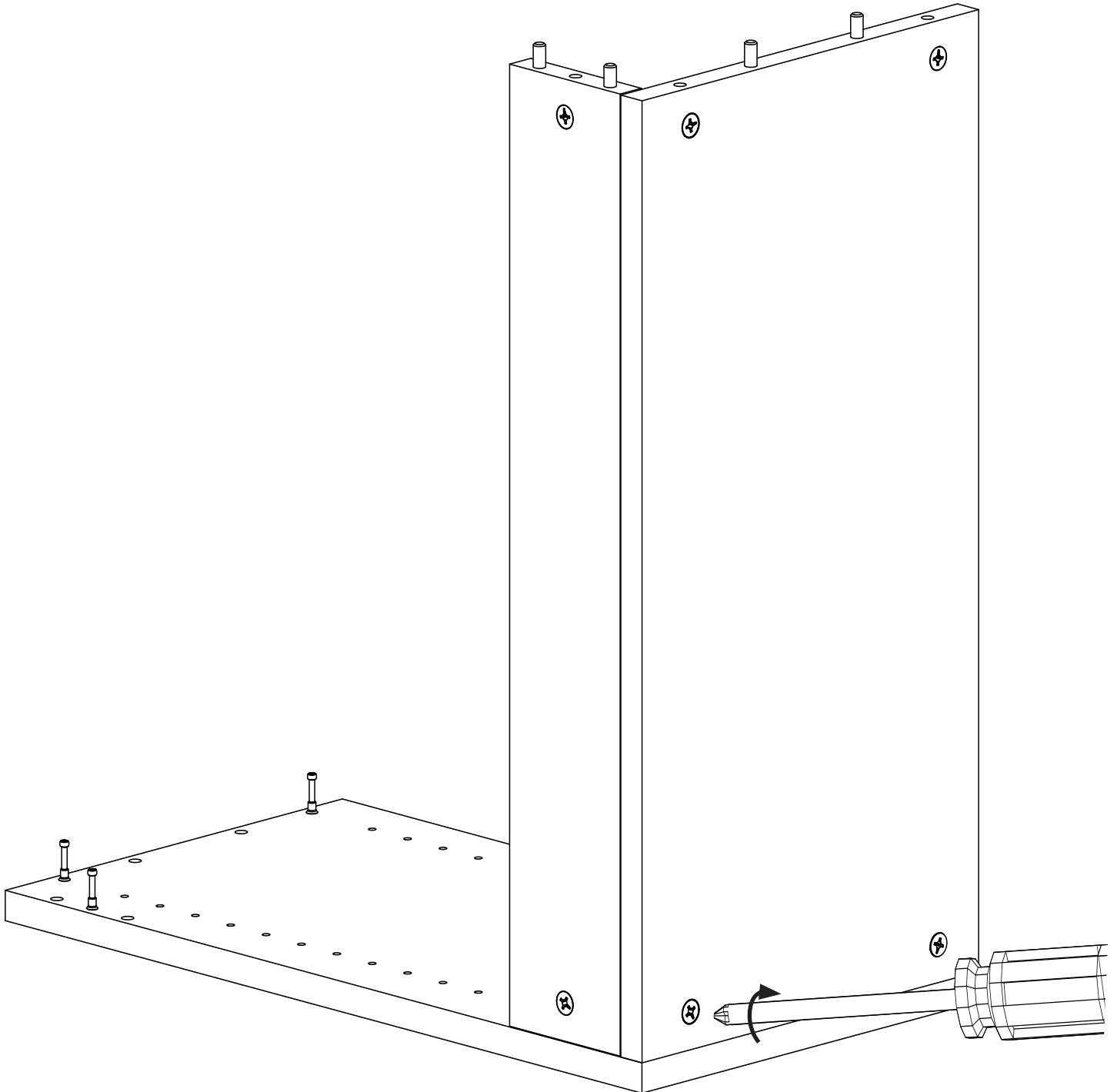

## Step 6

Insert remaining fixed shelf and cleat on the other side of the unit.

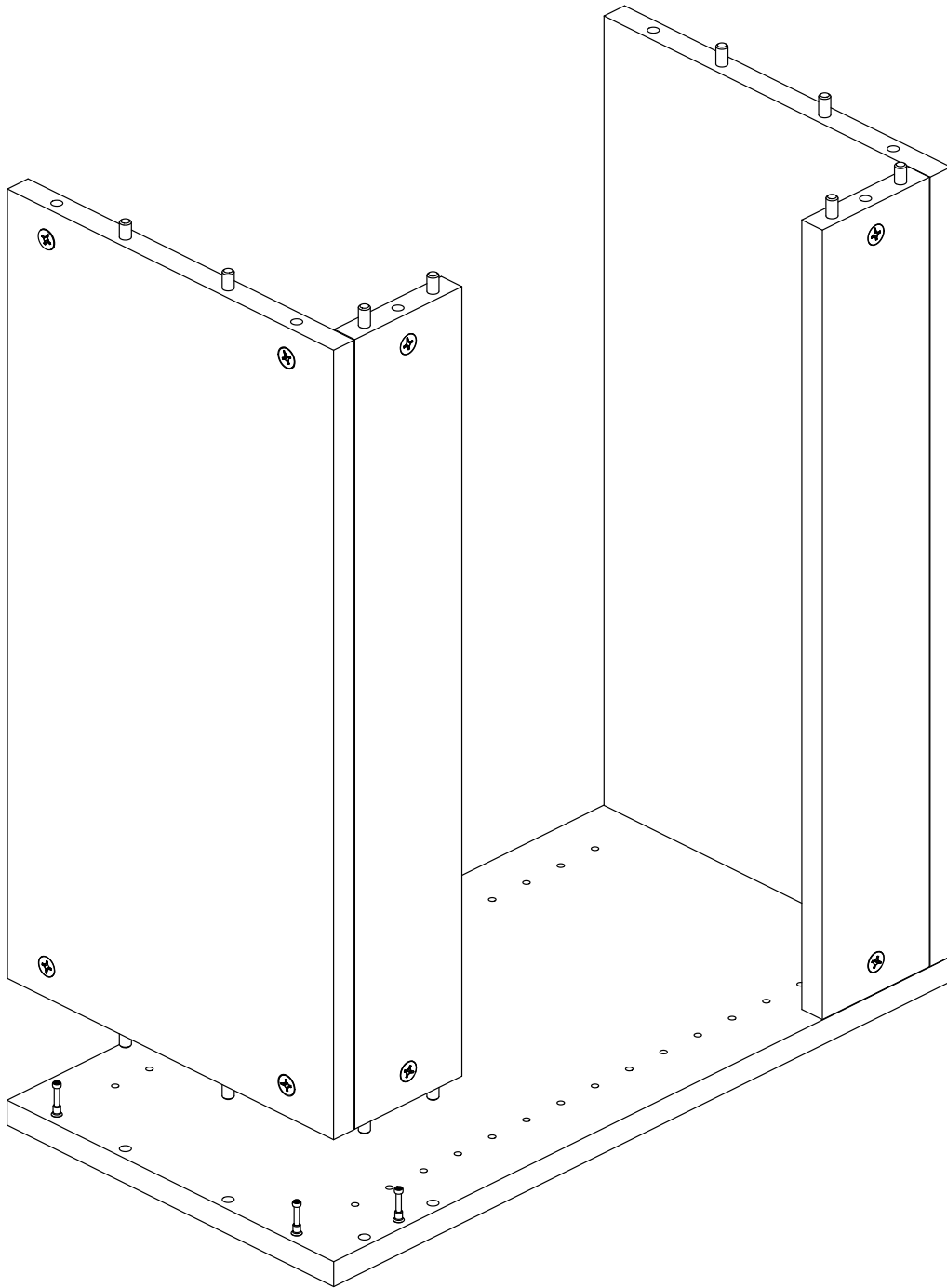



### Step 7

Tighten camlocks.

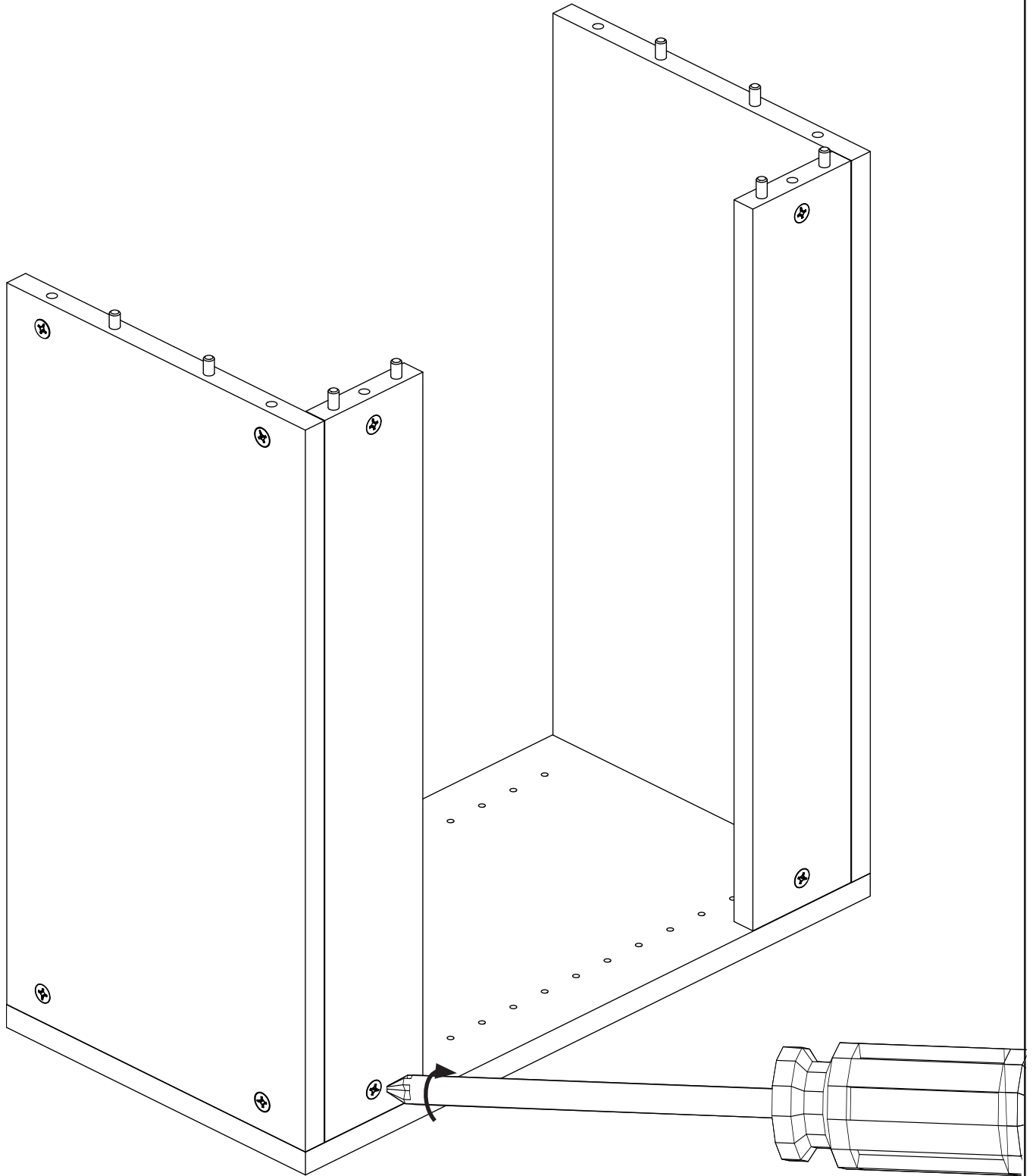

**Step 8**

Attach the remaining wall side panel to the top and tighten camlocks to secure unit.

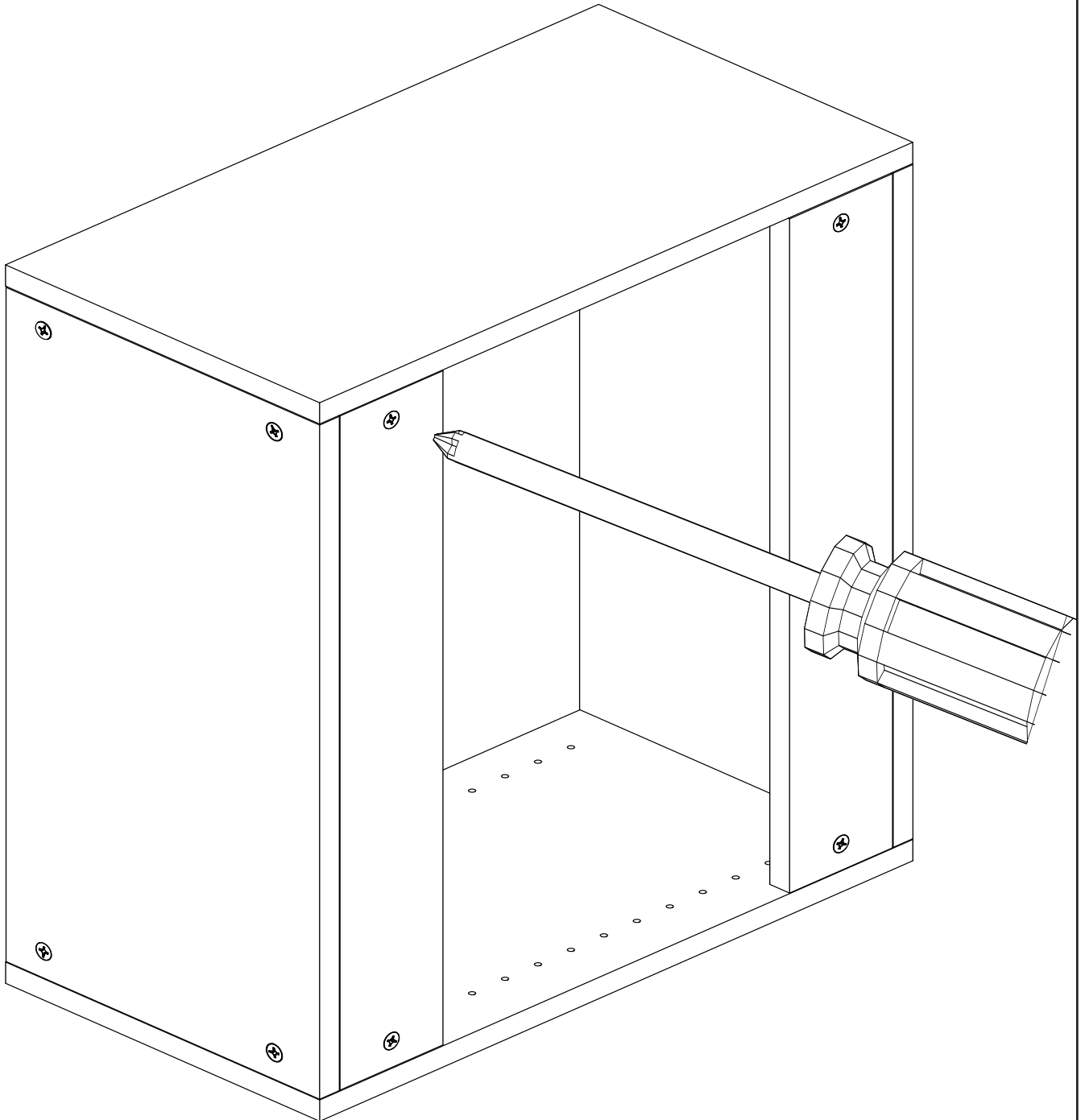



### Step 9

You have finished the wall unit shell.

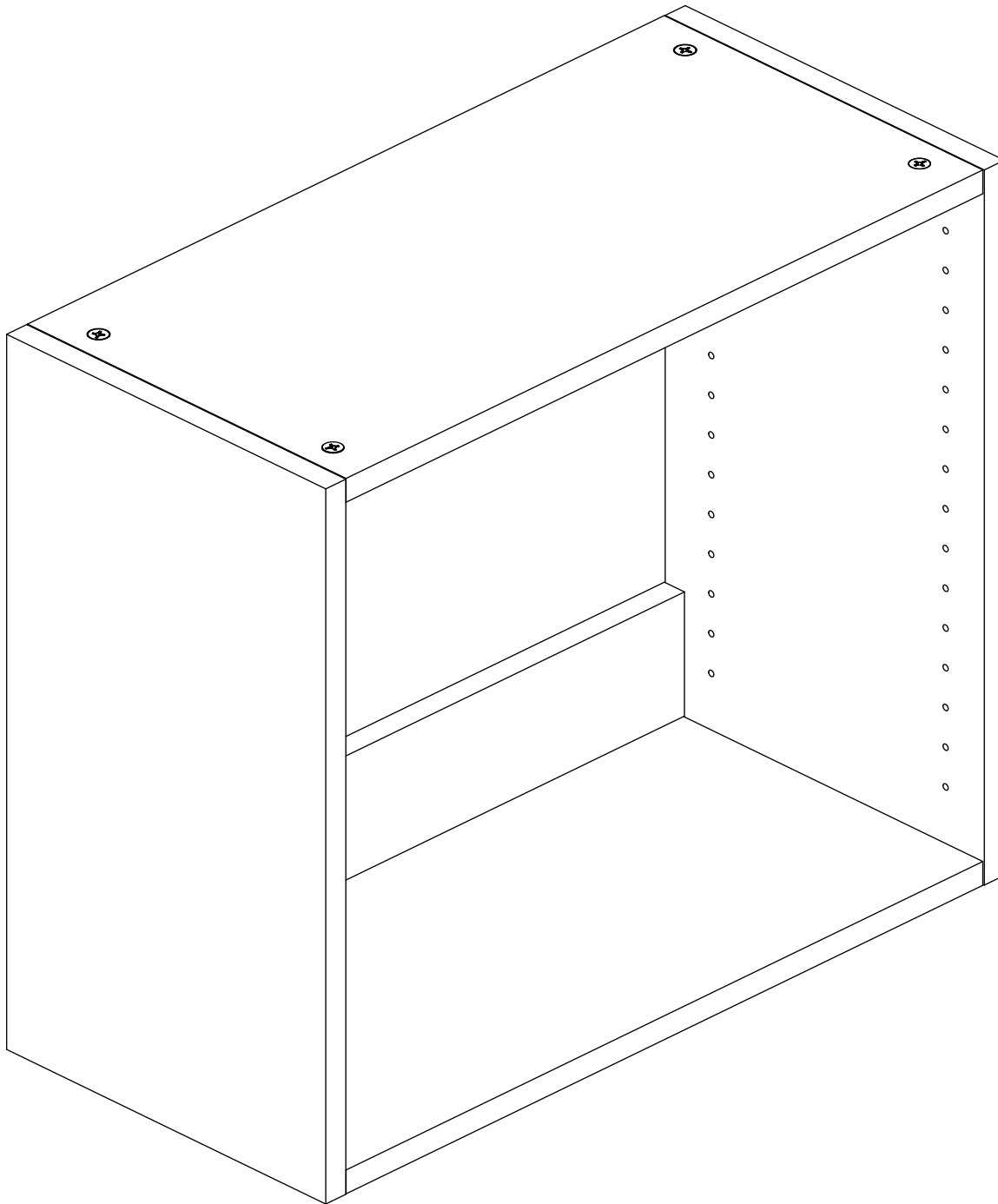

### Step 10

Using a stud finder, search for the studs in the wall and drill the screws through the top and bottom cleats in each unit into the studs. If there is only one stud, drill two screws into each cleat, one on top of the other.

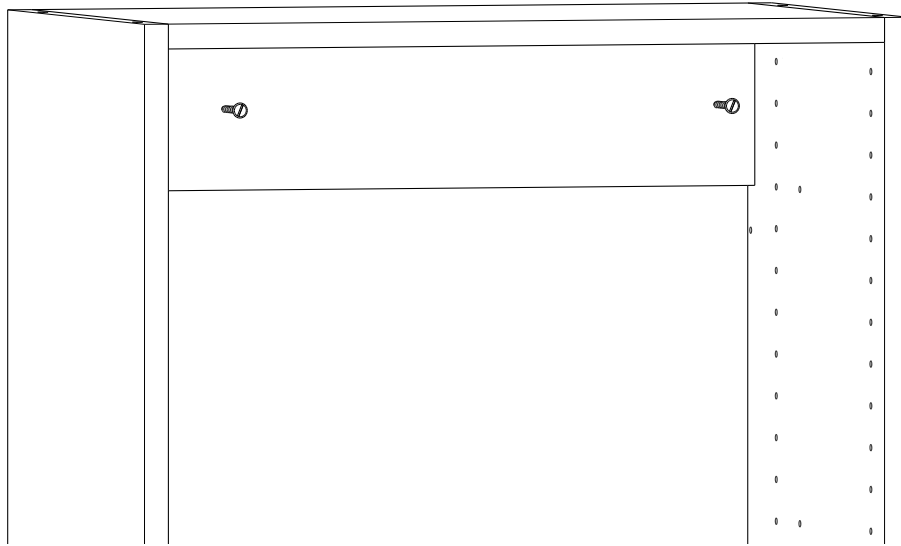

anchor screws  
x4

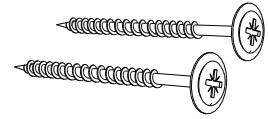



# Wall Variants

Following completion of the wall unit's shell you may now continue to whichever variant you are building from the styles shown below. Adjustable Shelf and Door instructions will be found in the appendix of this booklet.

Consult the table of contents on page 3 for where to proceed.

## APPENDIX

(A) Adjustable Shelves .....	49
(B) Door Kits .....	58
(C) Drawer Kits .....	66

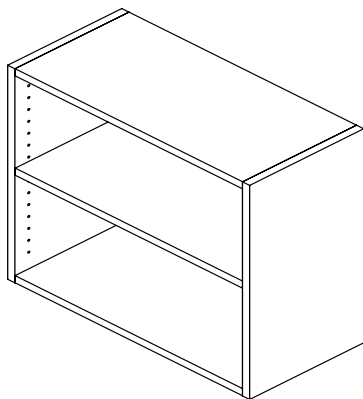

1 Shelf

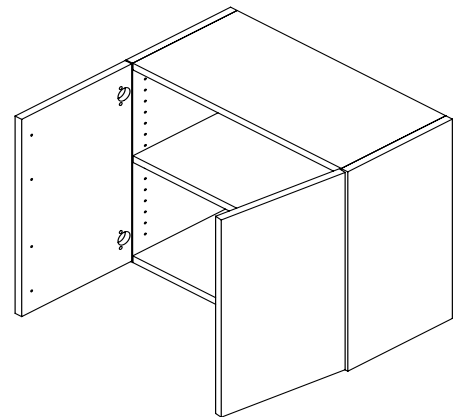

Doors  
1 Shelf



# Tall Assembly

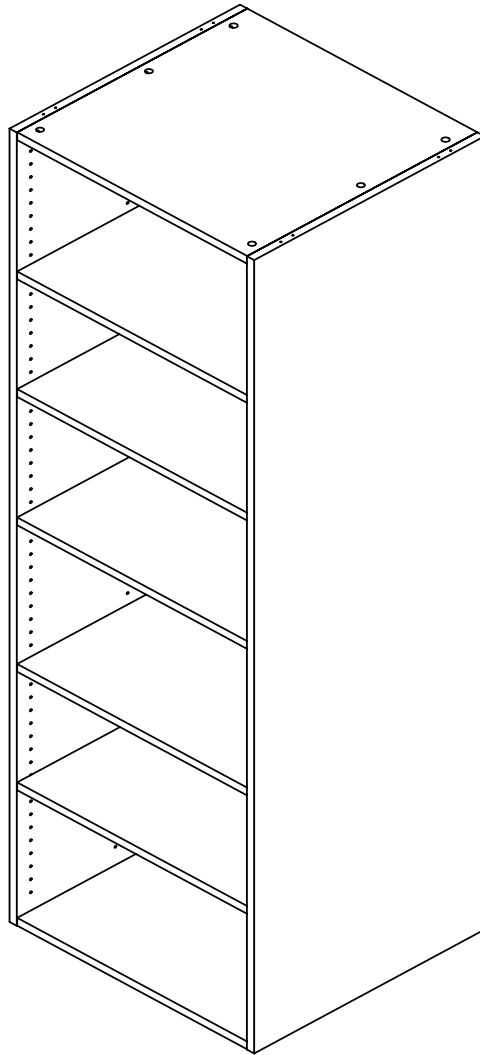



### Boxes Needed

GRG-TSP  
Tall Side Panels

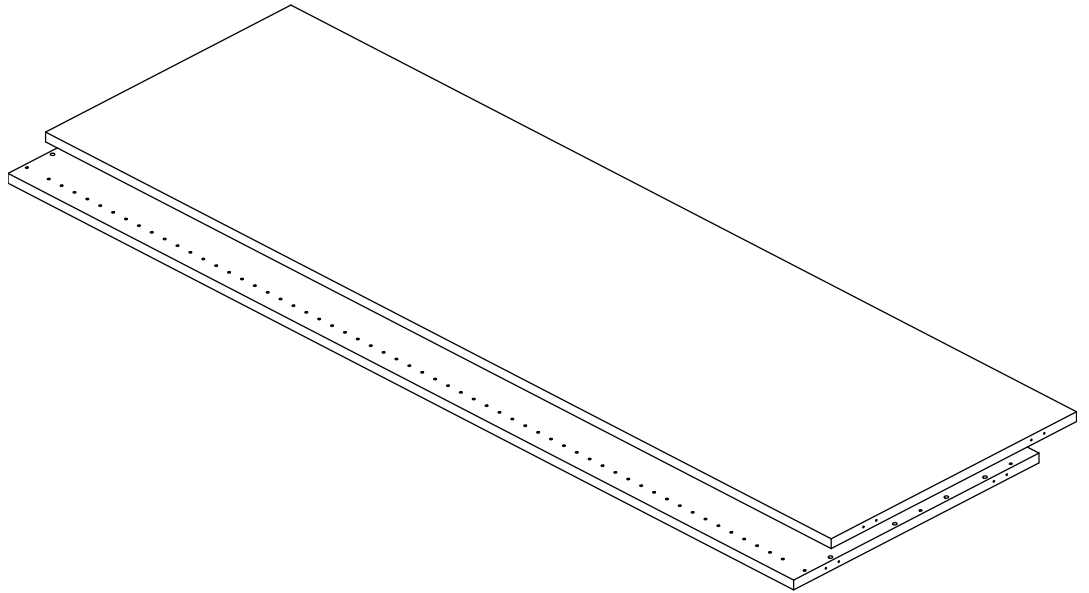

GRG-TFS  
Tall Fixed Shelf Pack

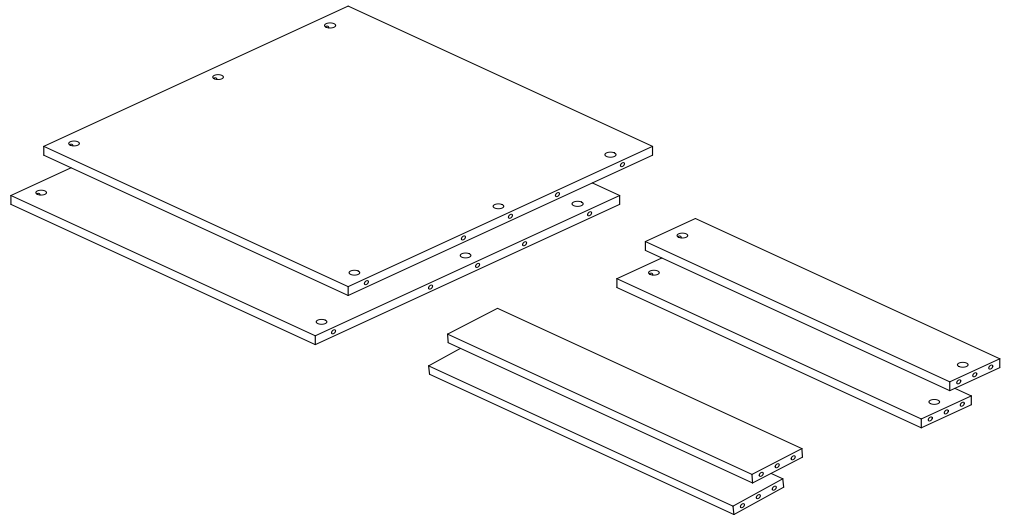

**Please hold additional boxes (doors) until after the wall shell is completed. Afterwards the door variant of the wall unit builders can proceed to the door instructions located in the appendix. See table of contents on page 3.**

Hardware Packs Needed  
GRG-HRDP-TFS

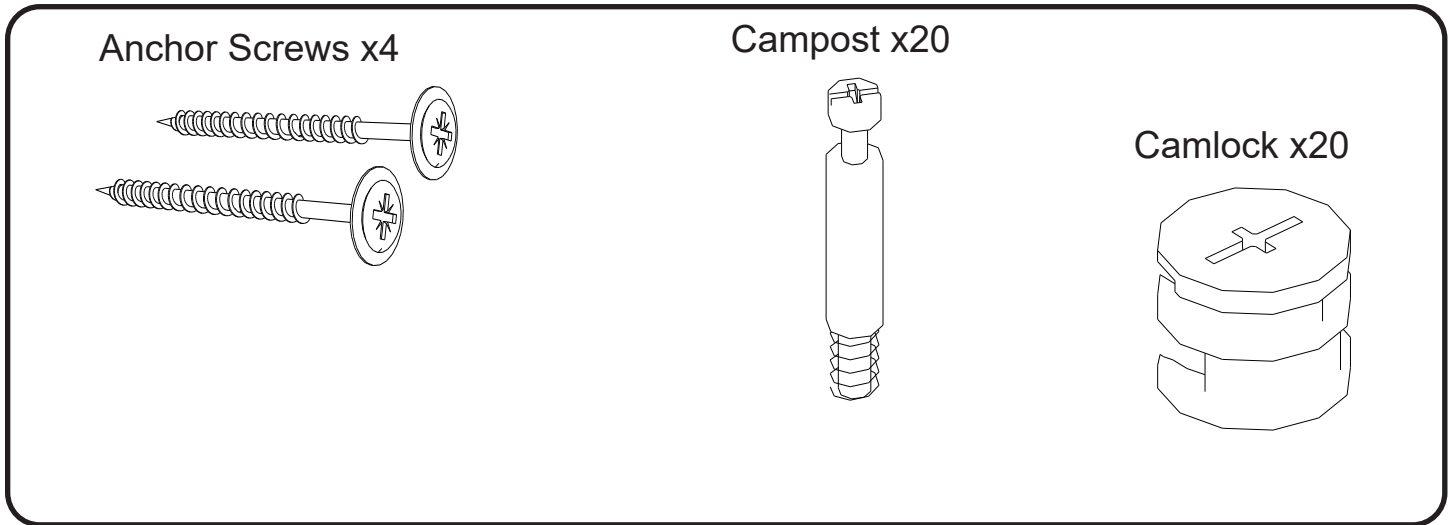

How to use the Cam lock system:

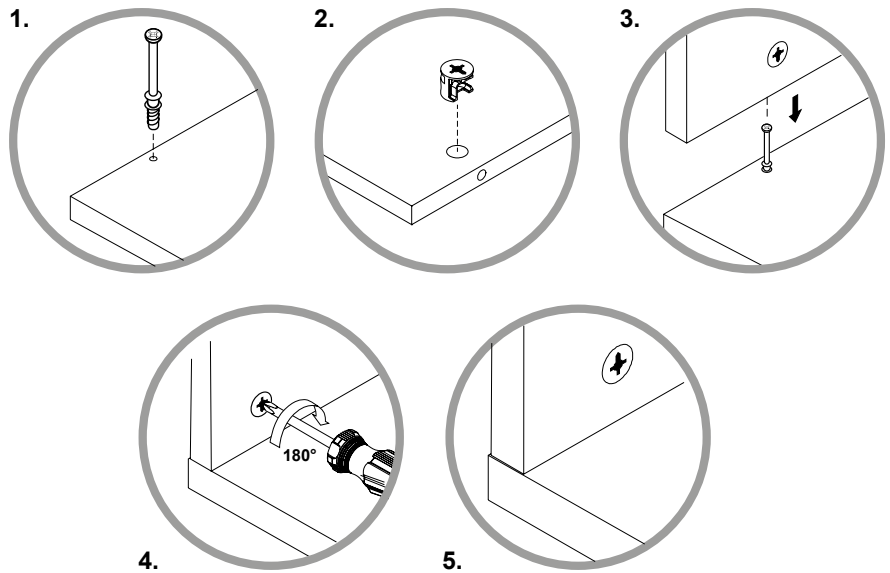

Tools needed

Rubber mallet



Drill

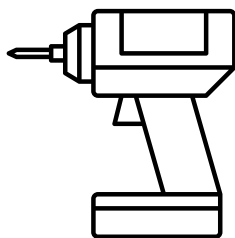

Level



Philips screw driver



Stud finder

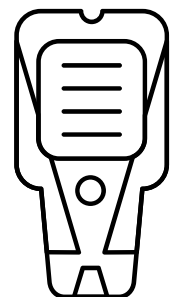

2 person assembly suggested



### Step 1

Take tall side panels from box GRG-TSP. Insert provided campost hardware and drill into spots circled below.

Campost

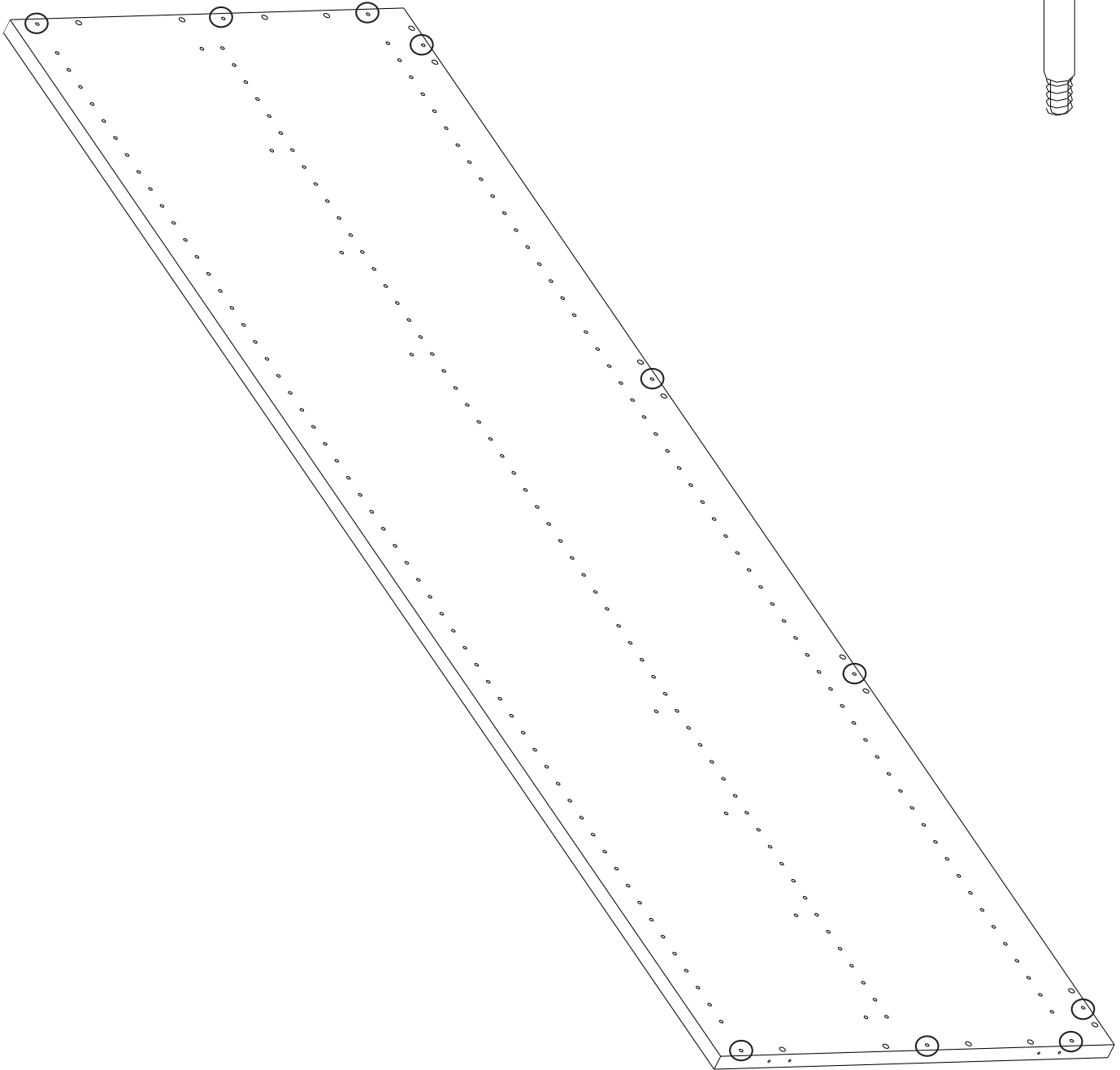
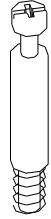

## Step 2

Repeat for other wall side panel.

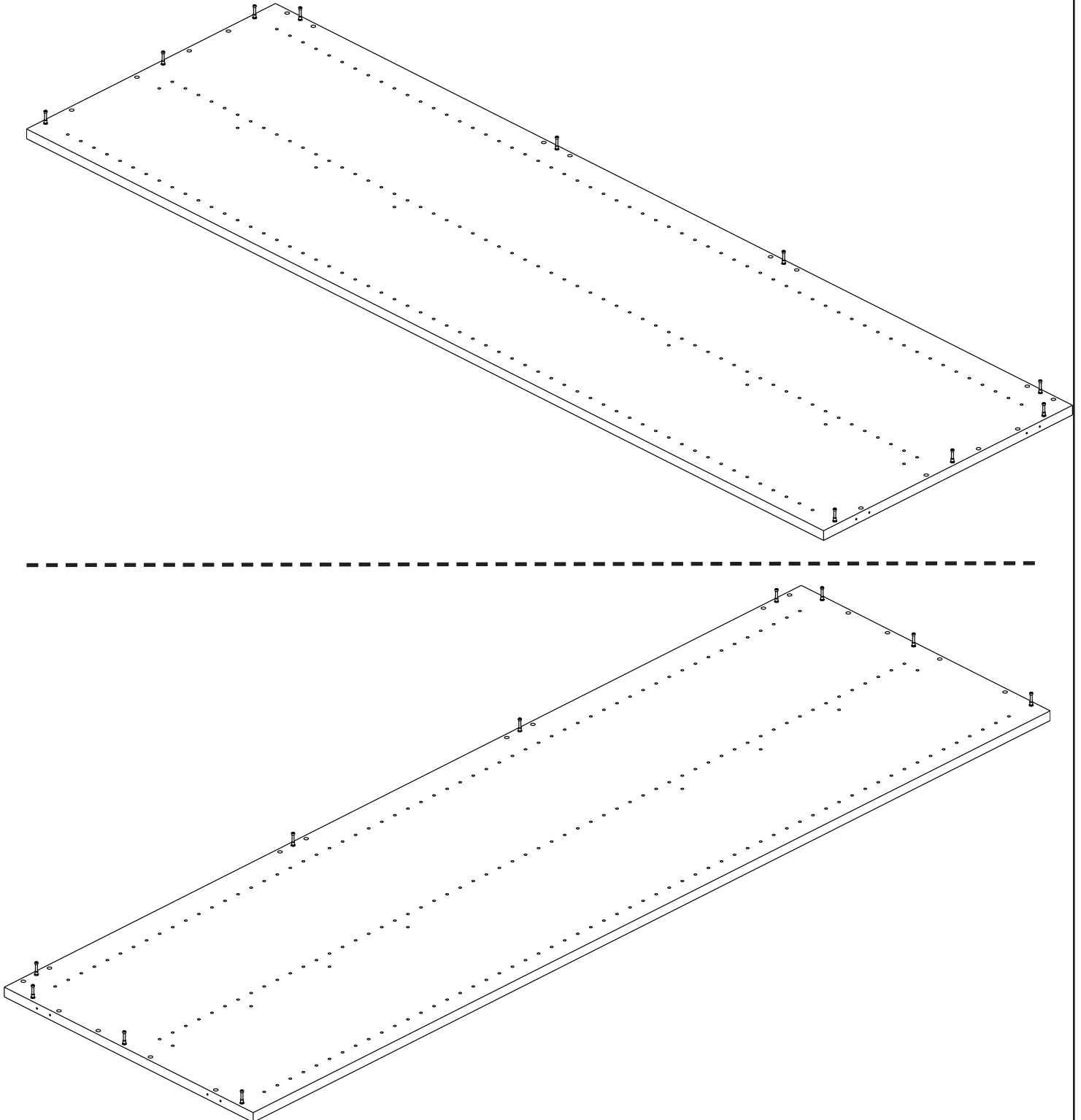



### Step 3

From the box GRG-BFS, insert camlocks in to the shelves and cleats, as shown below.

Camlock

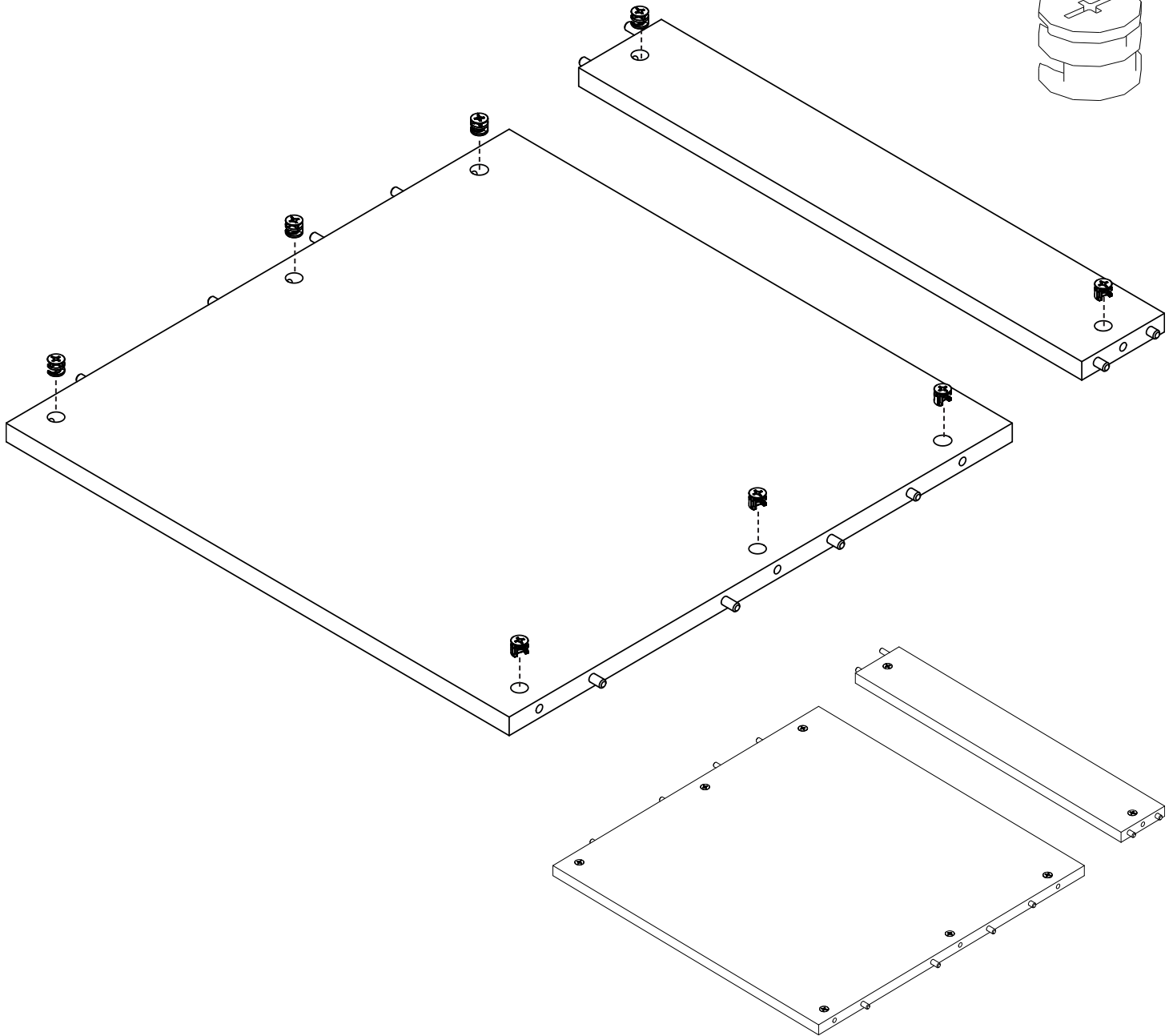
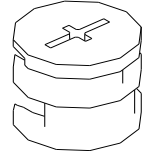

**Repeat Steps 2-3 for all the Fixed Shelves, Cleats and Floating Cleats**

**Step 4**

Insert cleat, floating cleat and fixed shelf into side panel. Tall units have all camlocks facing away from the inside.

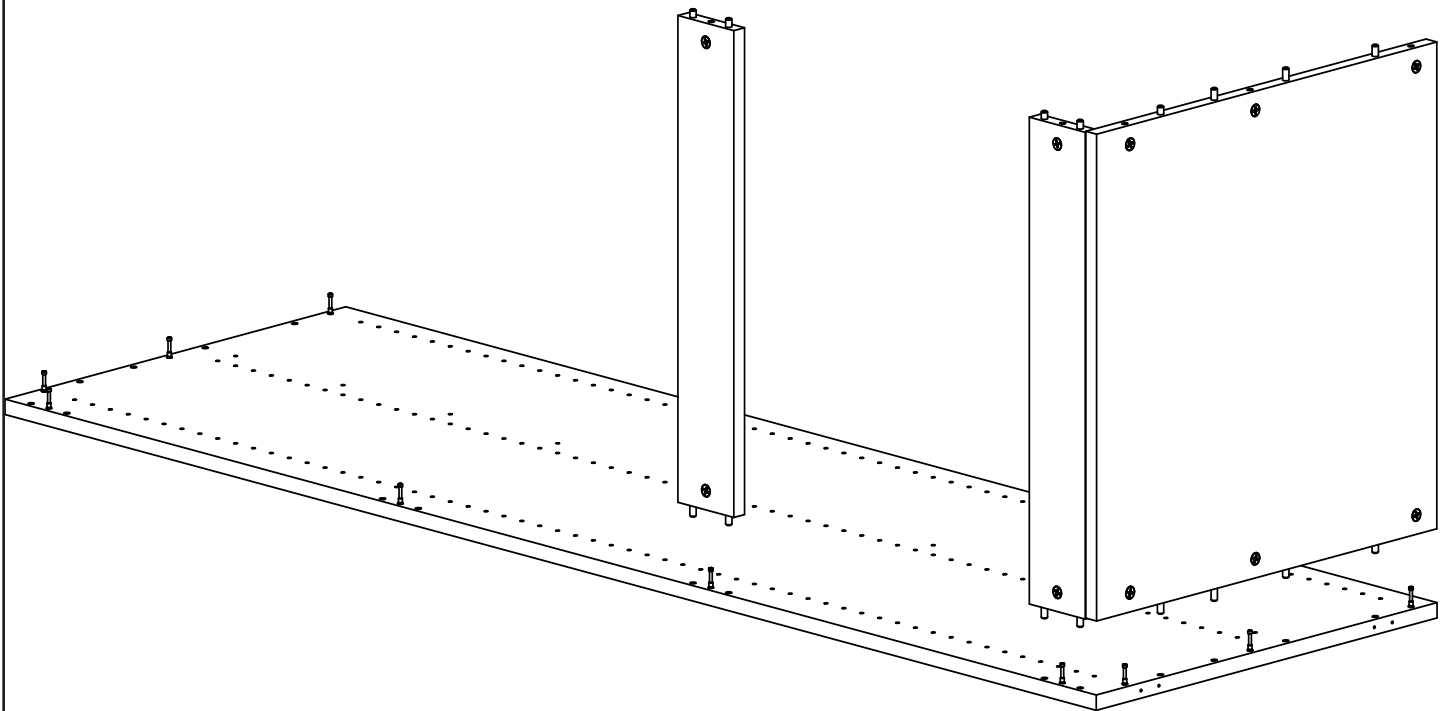



### Step 5

Tighten all camlocks connected to the tall side panel.

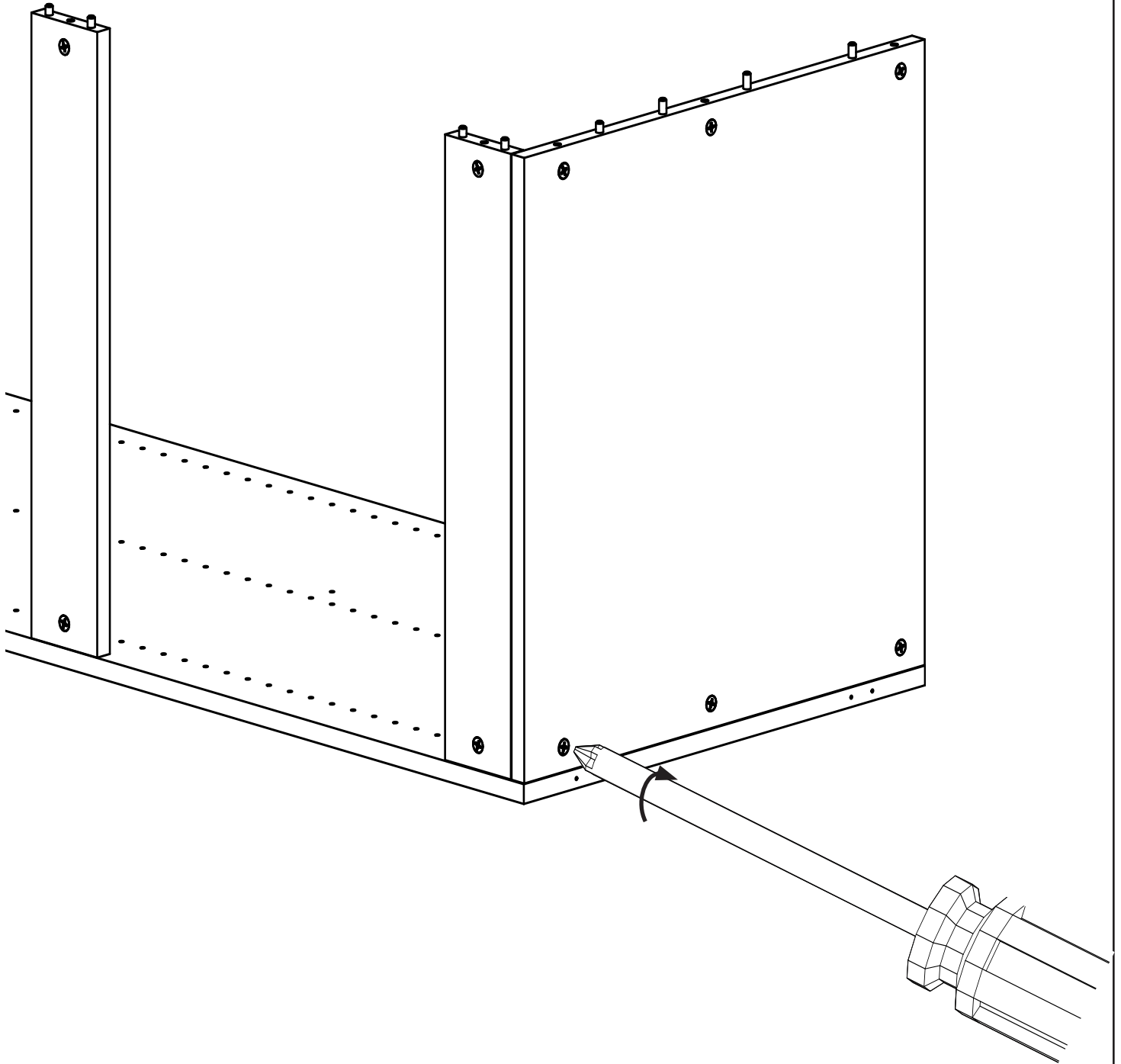



## Step 6

Repeat steps 4-5 on the opposite side of the prepared tall side panel.

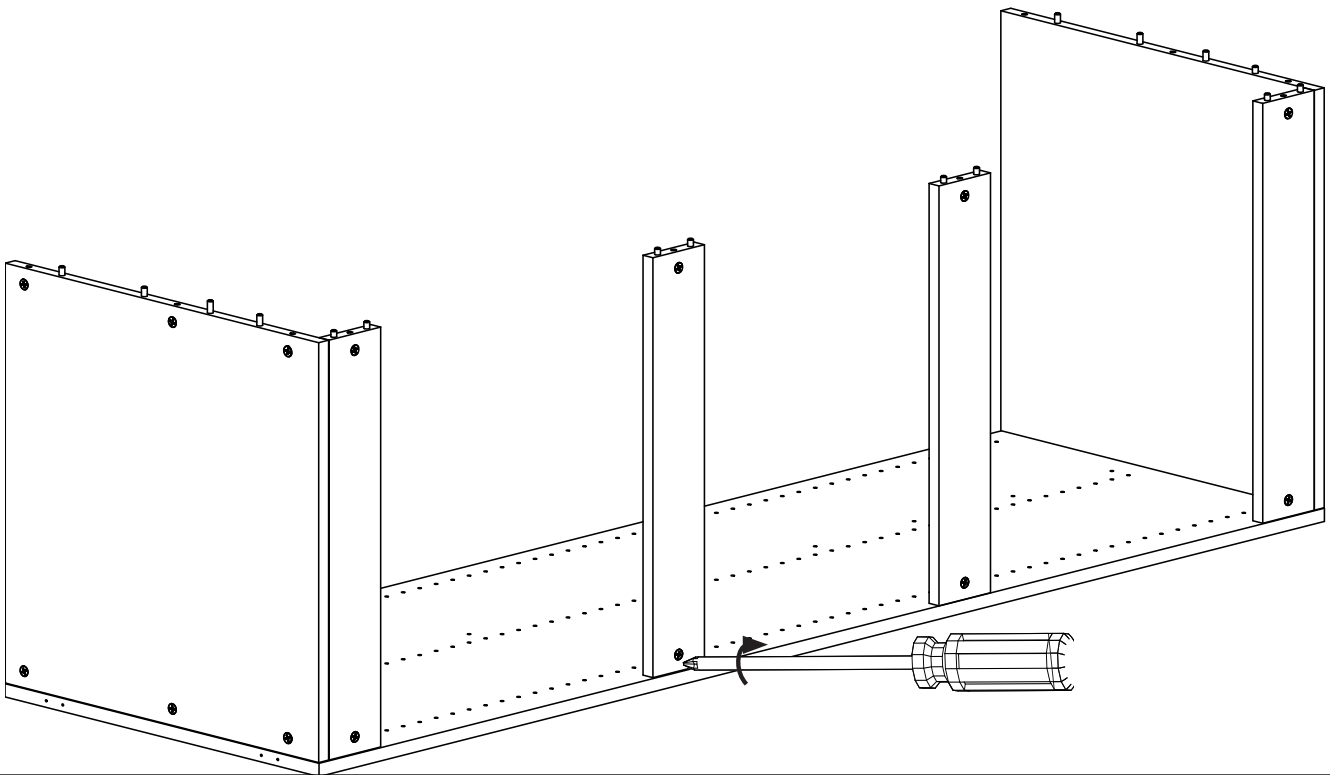
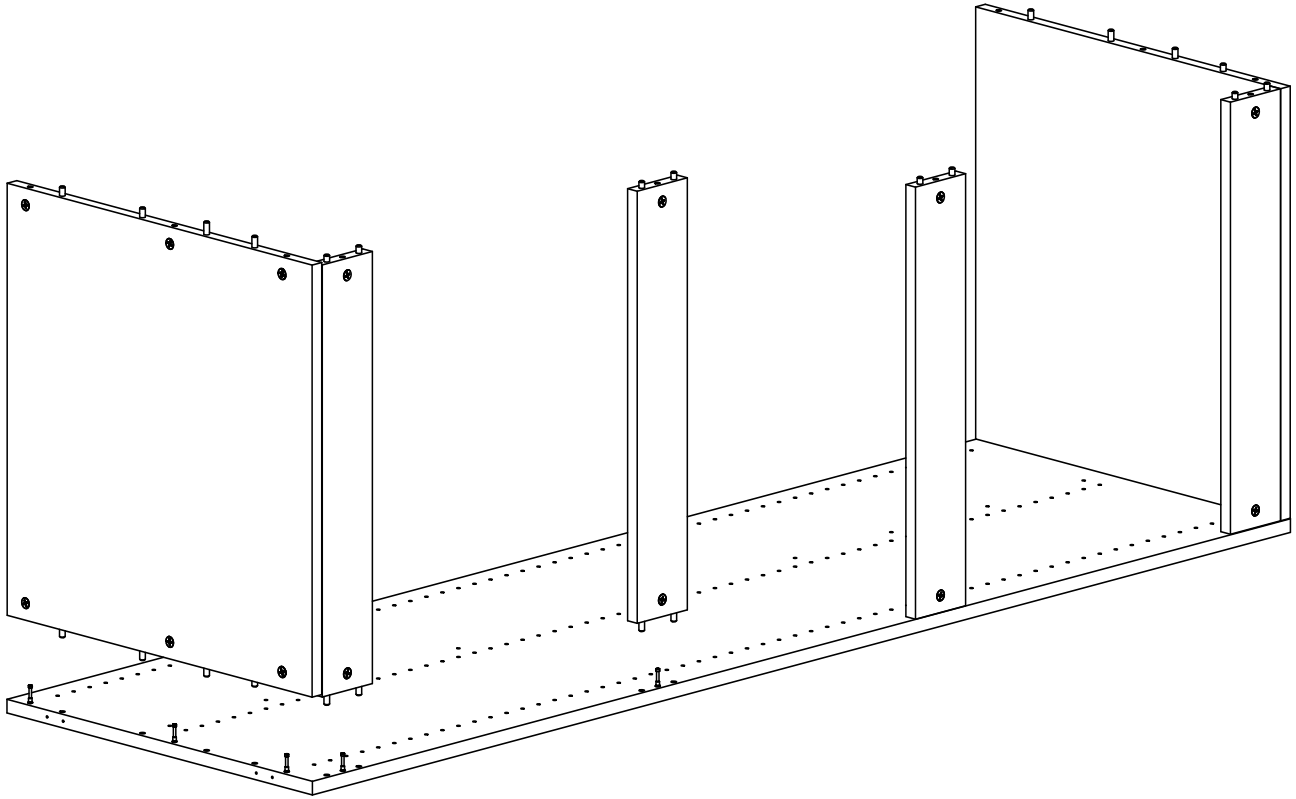



**Step 7**

Take remaining prepared tall side panel and carefully attach to the top of all fixed shelves and cleats.

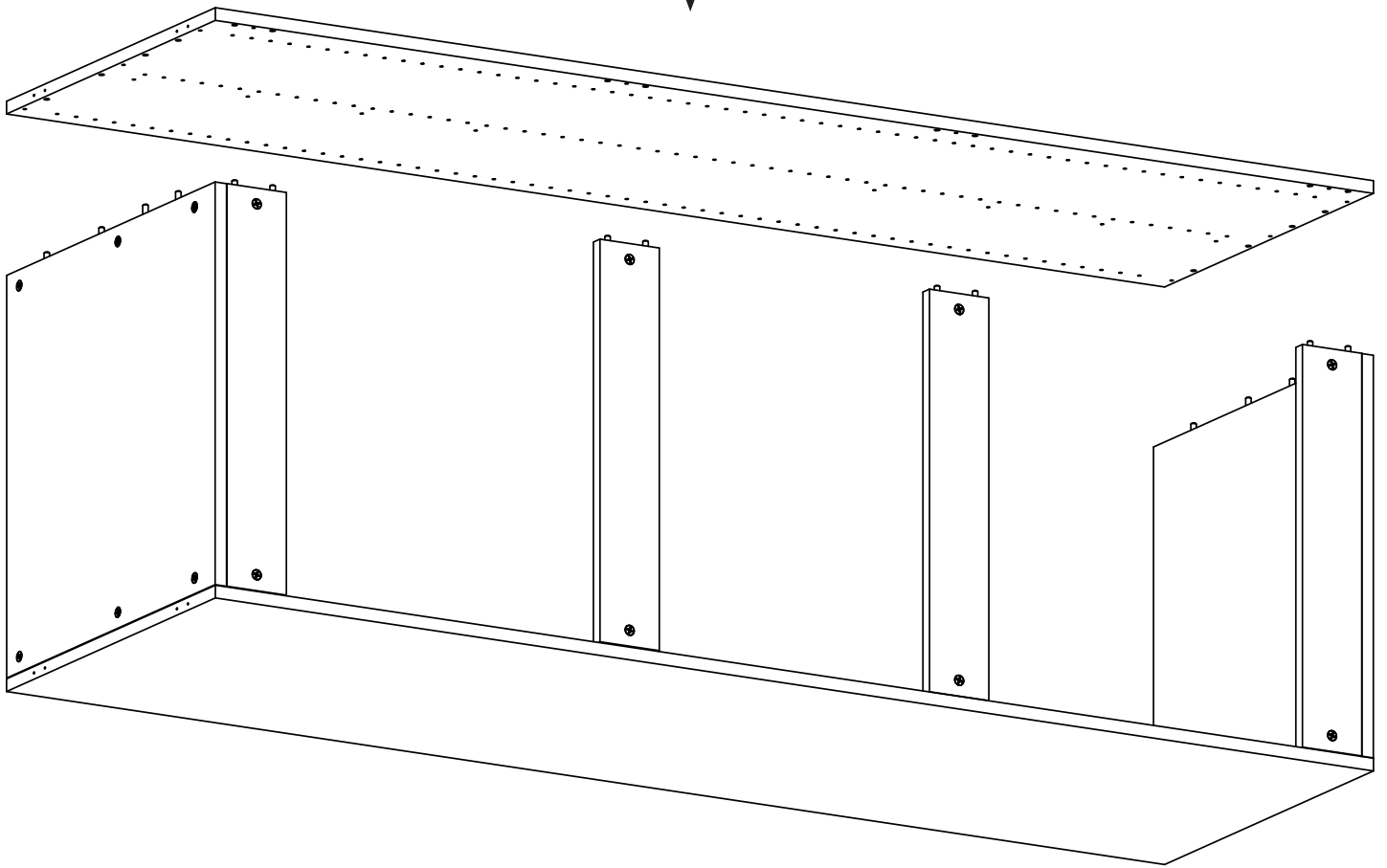

## Step 8

Tighten all camlocks attaching to the second tall side panel.

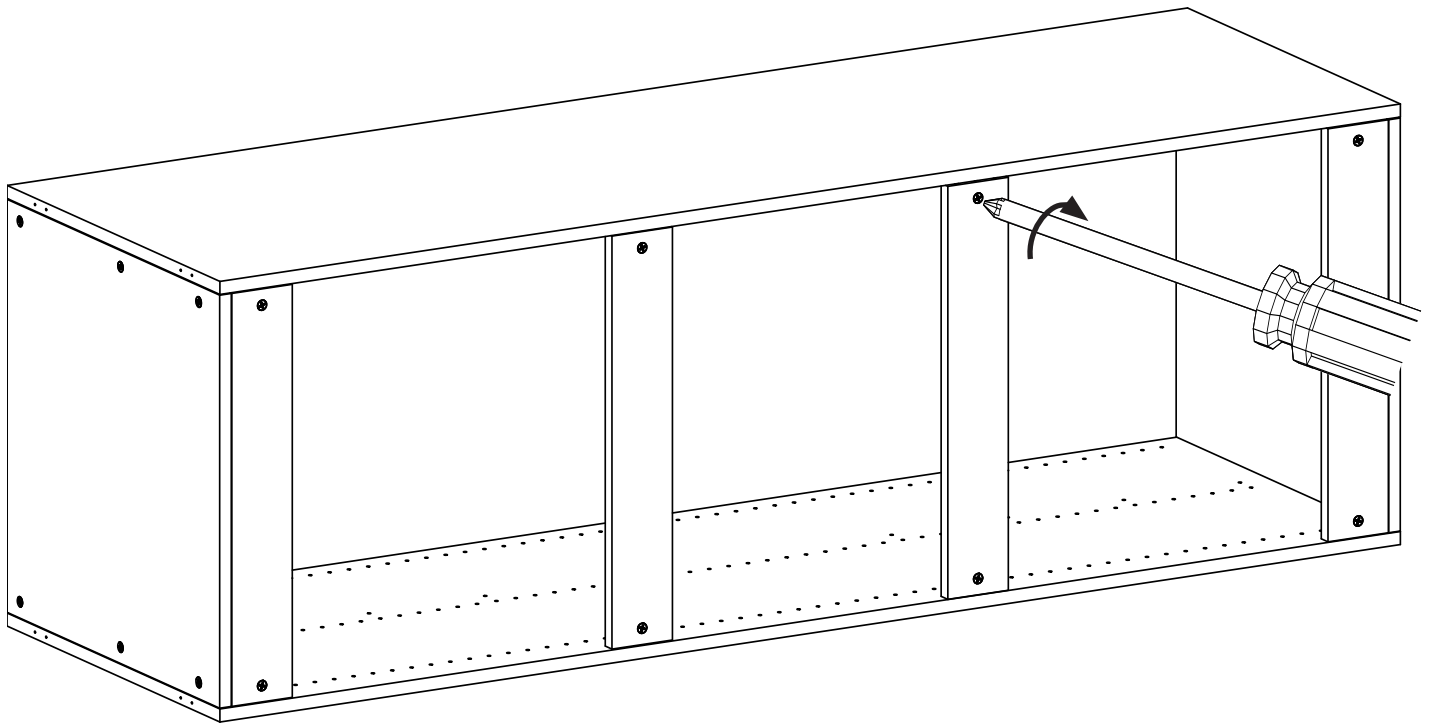



### Step 9

You have finished the tall unit shell.

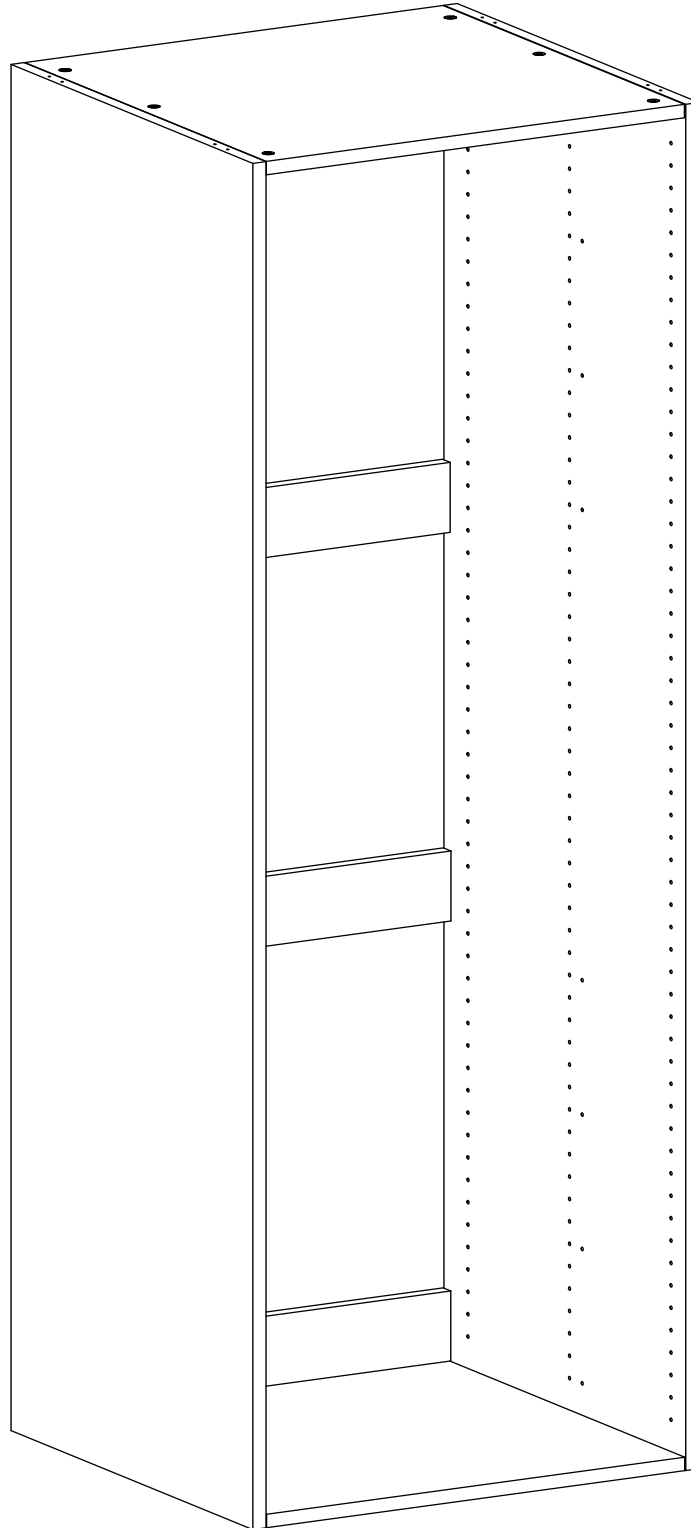

### Step 10

Open leg hardware pack (HRD-552). Lay each unit down carefully and use the pre-drilled pilot holes on the bottom of each side panel to align your legs correctly and drill them into place. Repeat as necessary.

Leg Kit

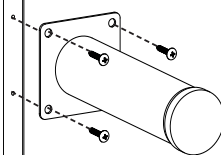
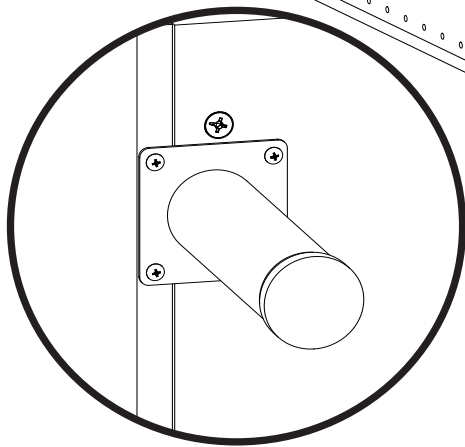
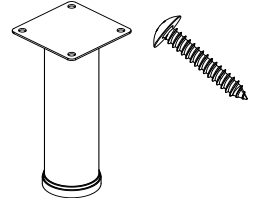



### Step 11

Using a stud finder, search for the studs in the wall and drill the screws through the top and bottom cleats in each unit into the studs. If there is only one stud, drill two screws into each cleat, one on top of the other.

anchor screws  
x4

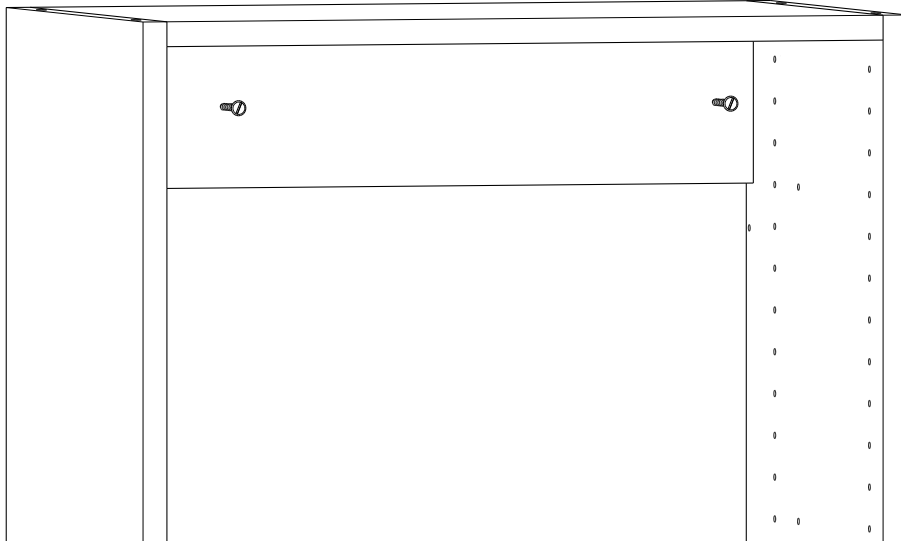
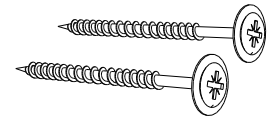

# Garage Variants

Following completion of the wall unit's shell you may now continue to whichever variant you are building from the styles shown below. Adjustable Shelf and Door instructions will be found in the appendix of this booklet.

Adjustable shelves

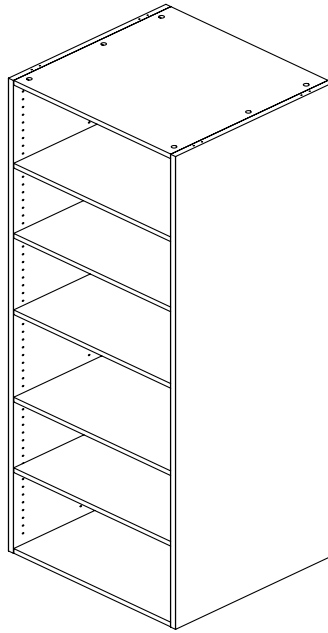

Drawers

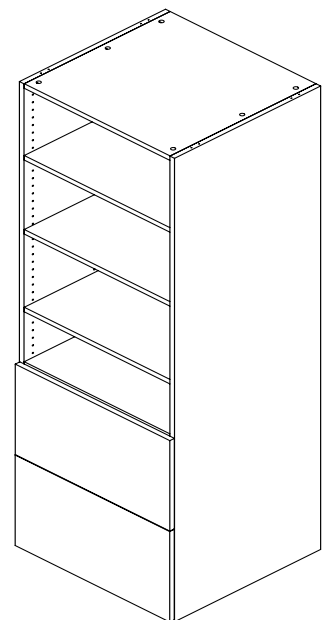
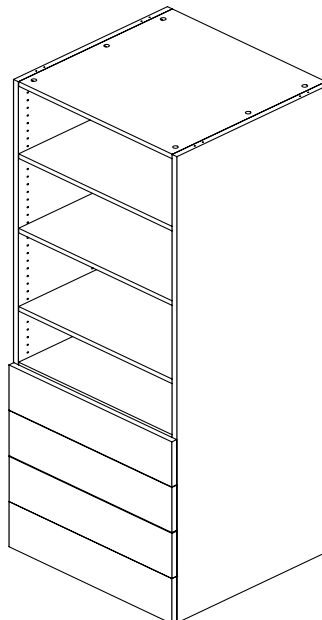
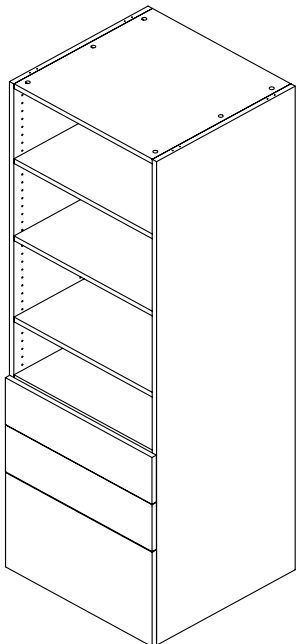



Doors

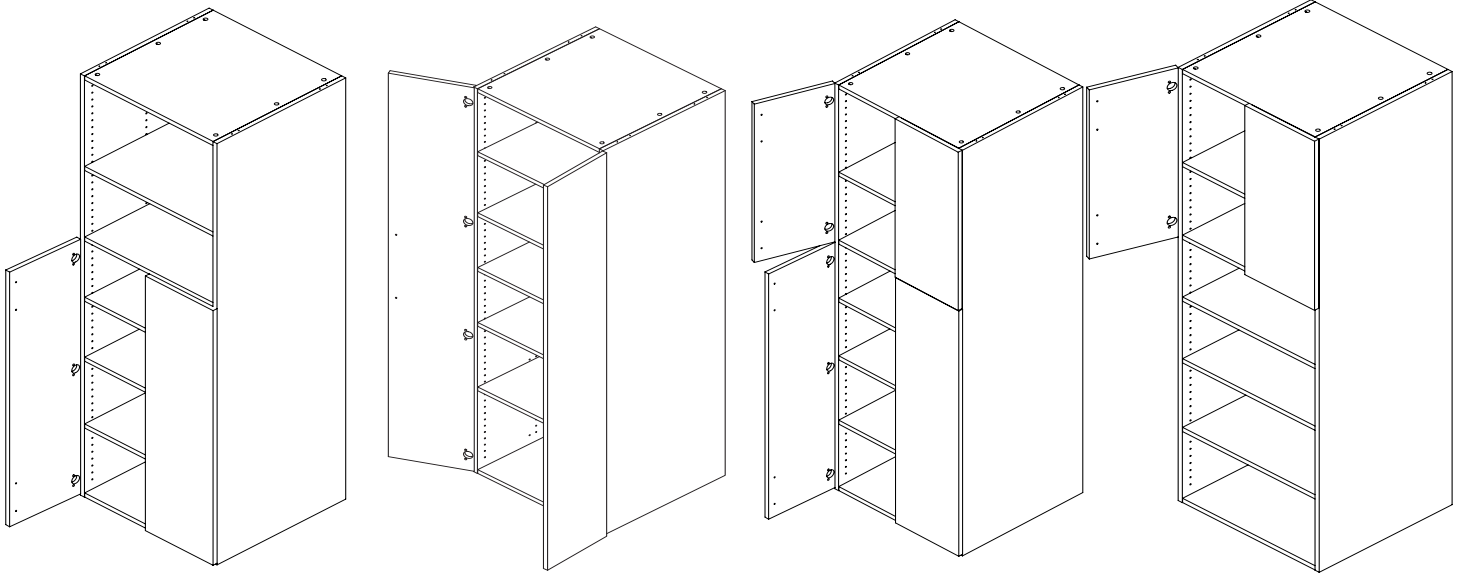

---

Doors + Drawers

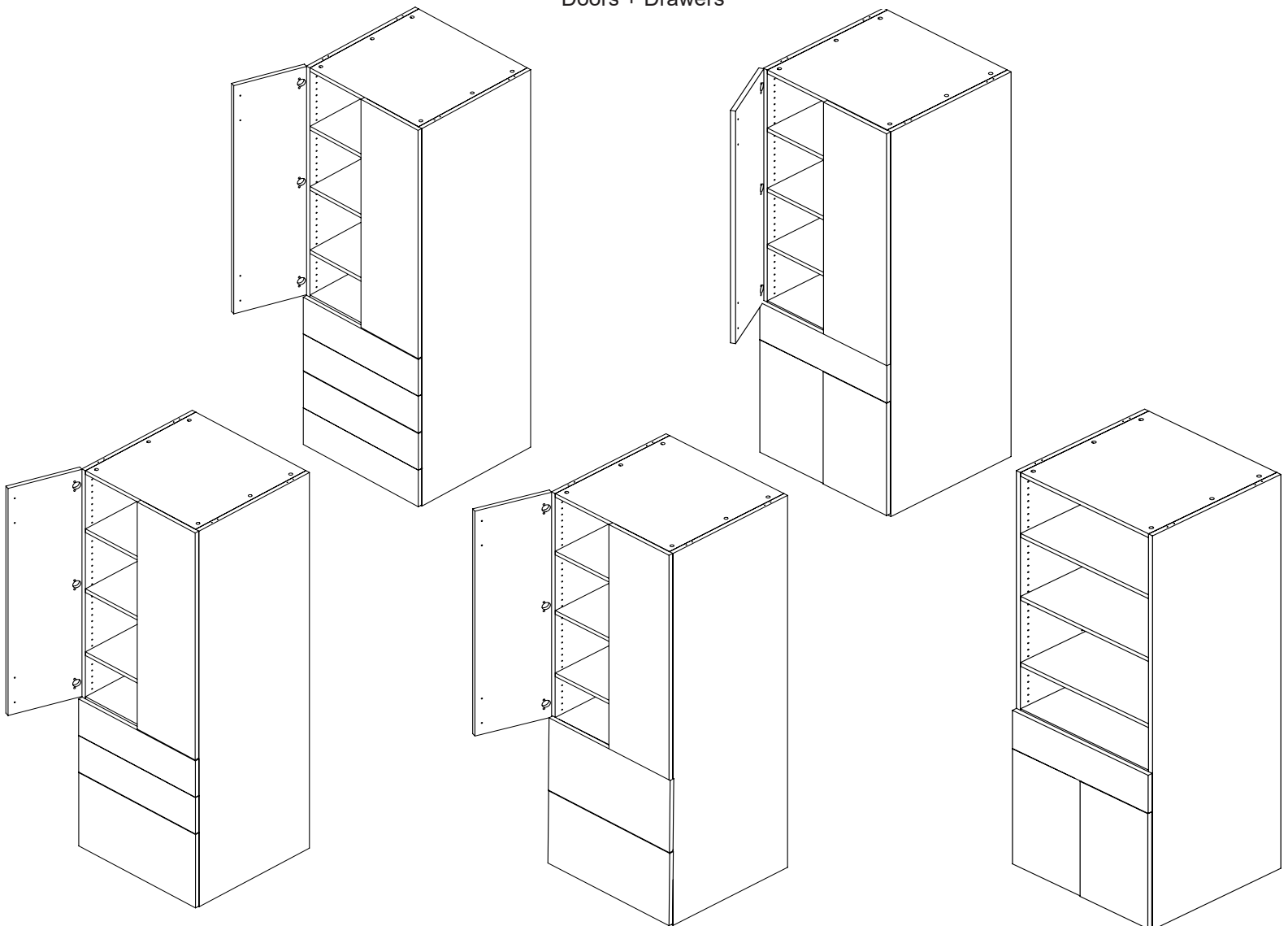



# Adjustable Shelves

## APPENDIX A

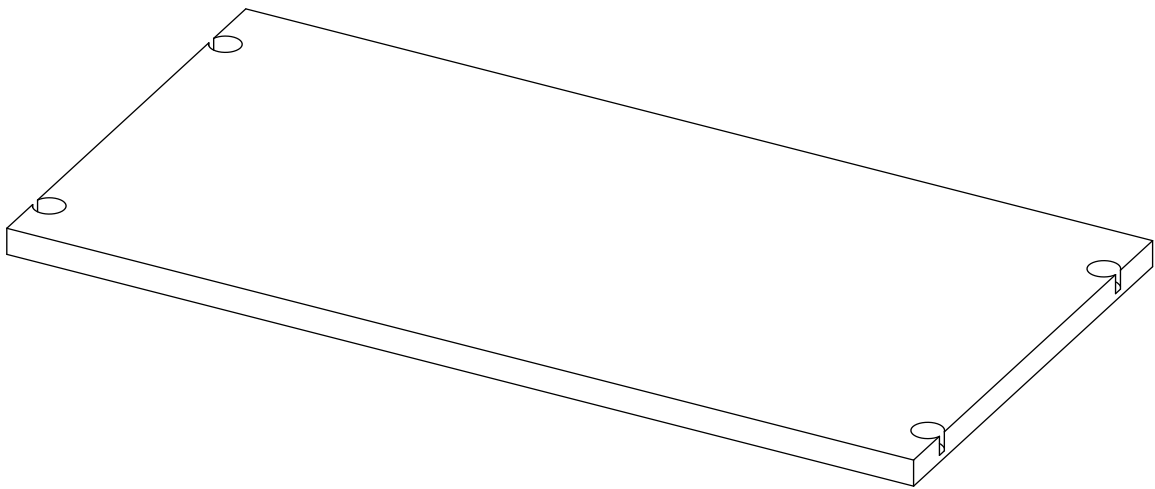
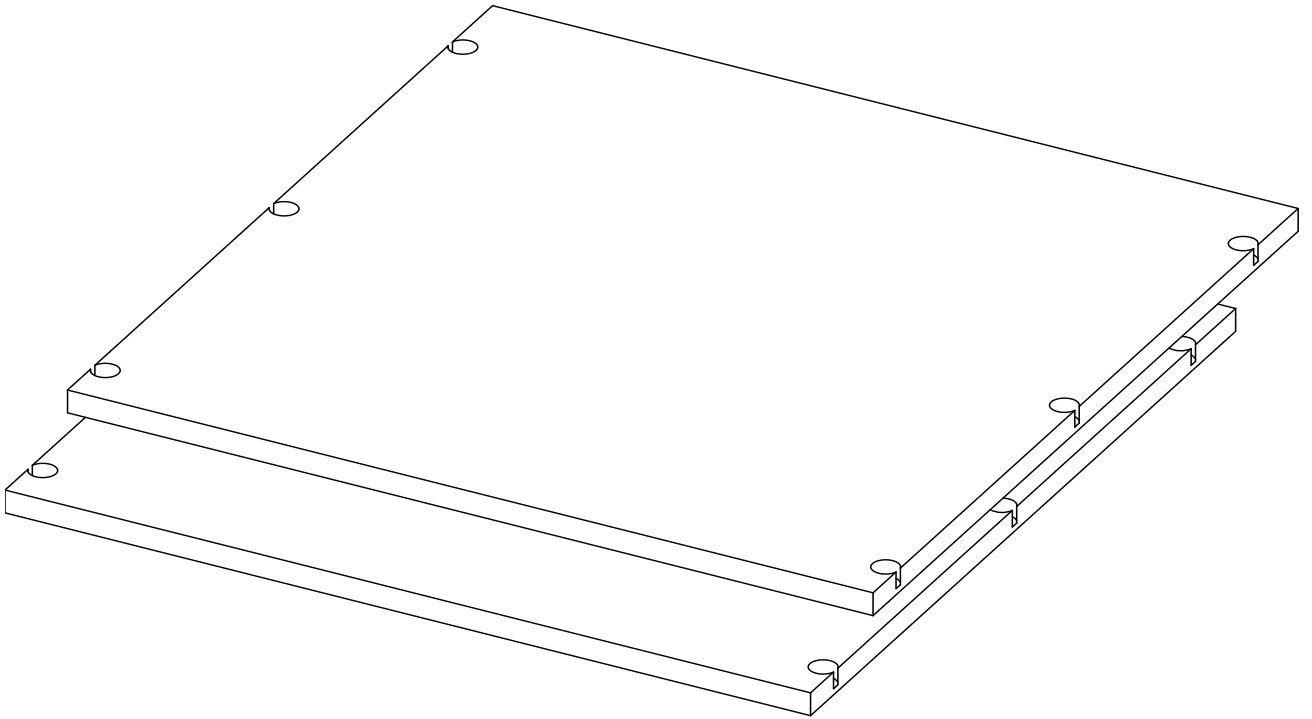



It is recommended to install adjustable shelves **AFTER** installing all doors and drawers in each unit. The doors and drawers will act as a guide of where to install adjustable shelves to prevent any mistakes. Please continue only after verifying no further drawers or doors will be attached.

## Boxes Needed

GRG-AS  
(Come in packs of 2 or  
3)

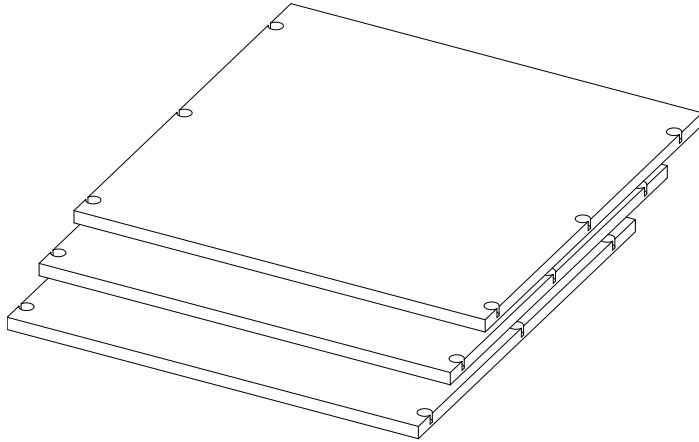

NG-WFS  
(Wall Fixed Shelf pack  
comes with third shelf to  
be used as adjustable  
shelf)

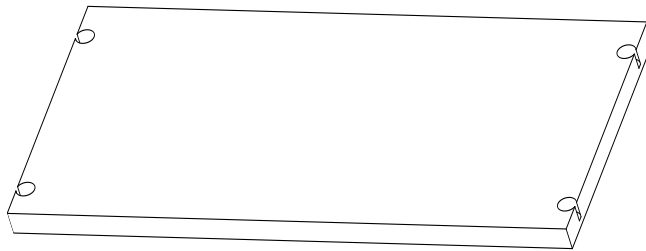



Hardware Packs Needed  
HRDP-3AS

Screw dowel x18

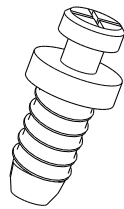

Wedgefix x18

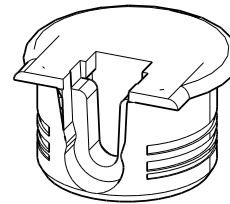

OR

Hardware Packs Needed  
HRDP-2AS

Screw dowel x12

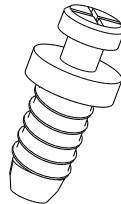

Wedgefix x12

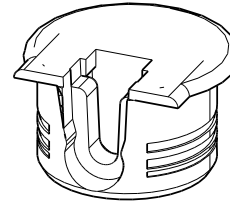

**Please Note: If applicable, for any built Wall Units, one shelf and extra hardware was set aside. You will be using set aside hardware for the installation of this specific shelf. Continue following after locating hardware.**

Tools needed

Rubber mallet



Drill

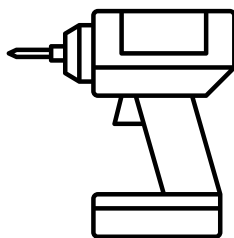

Level



Philips screw driver



Stud finder

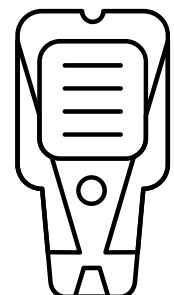

### Step 1

Insert provided wedgex clips into adjustable shelves (wall adjustable shelves have only two slots on each side). Have all open slots of the wedgex hardware face outward.

Wedgex

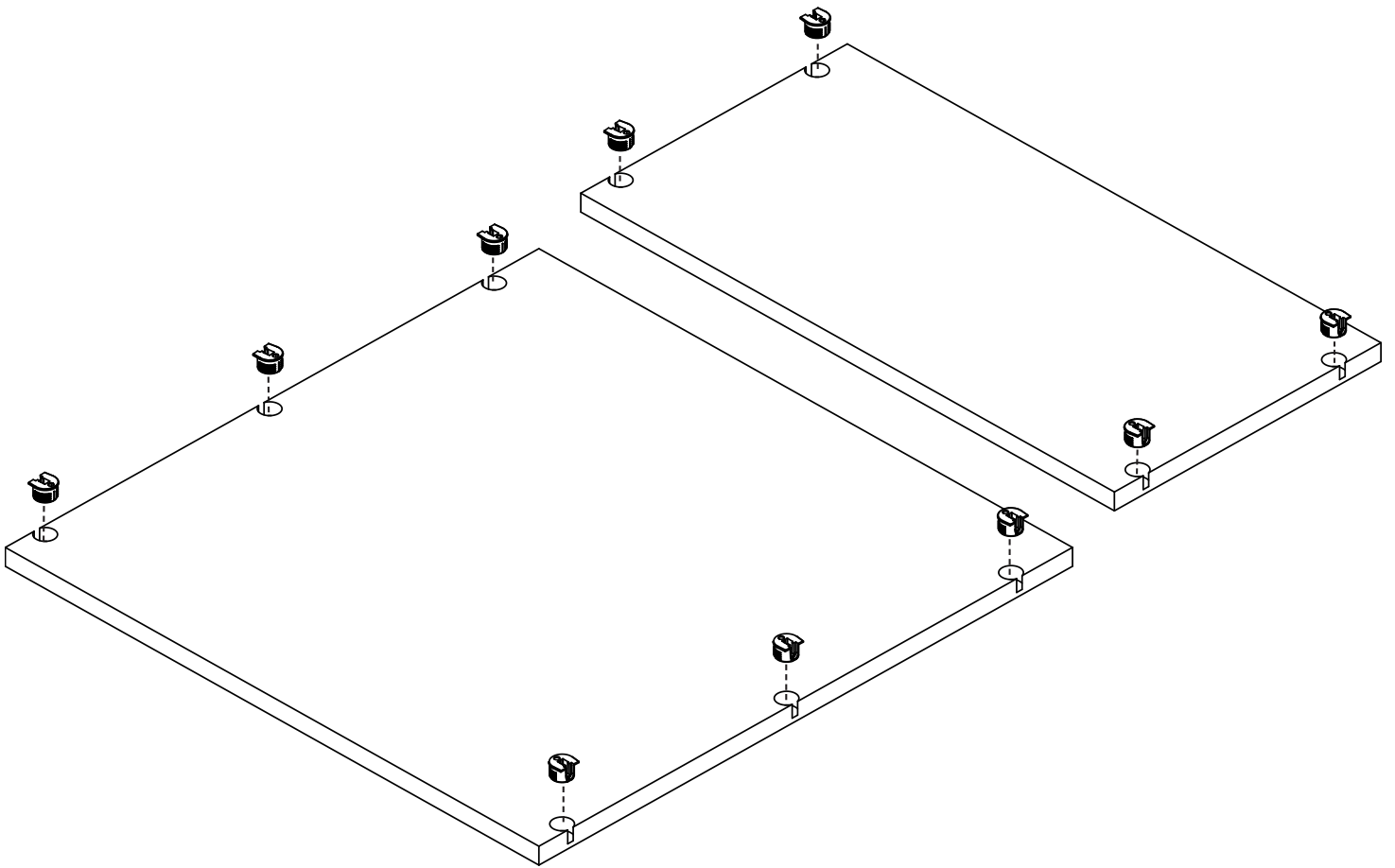
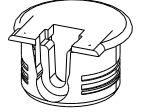



### Step 2

Insert and drill provided screw dowels into side panels. Ensure all three (two for wall unit) screw dowels are lined up evenly and correctly positioned where the shelf should go.

Screw Dowel

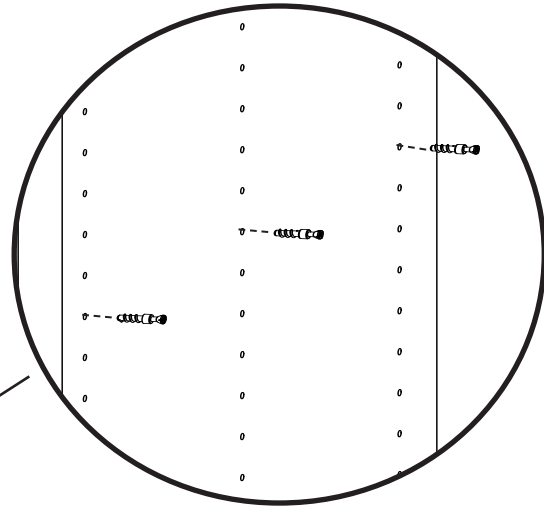
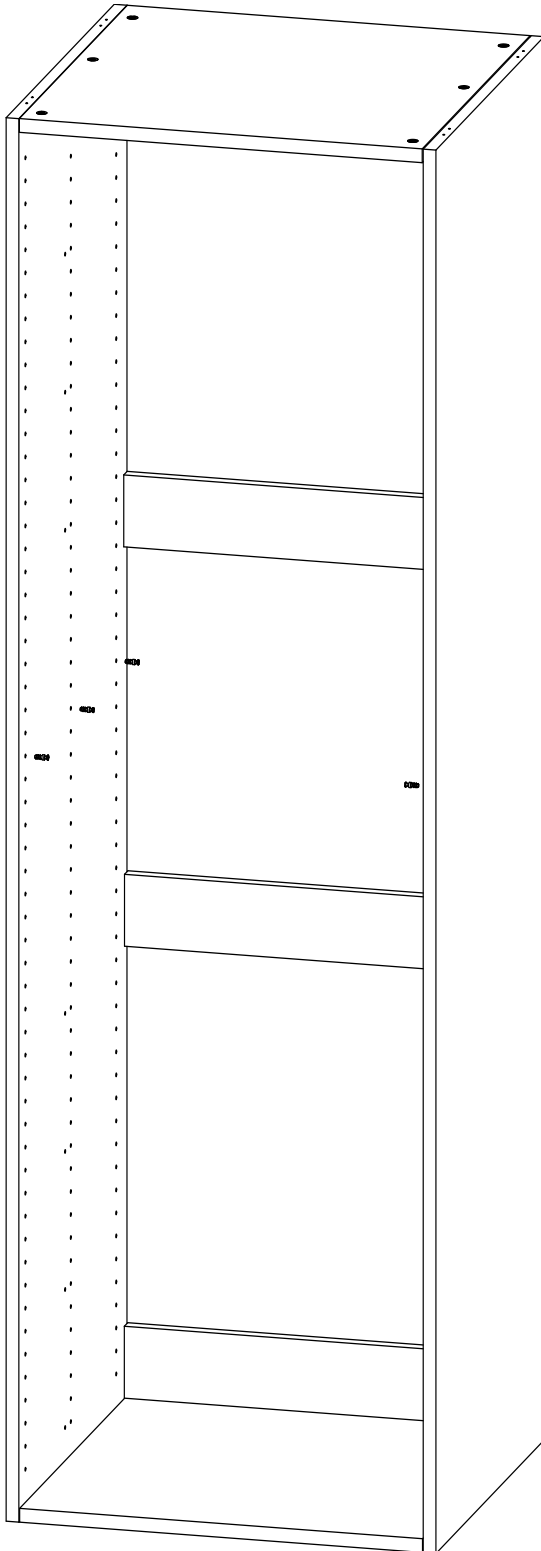
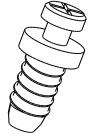



### Step 3

Repeat for other side panel.

Screw Dowel

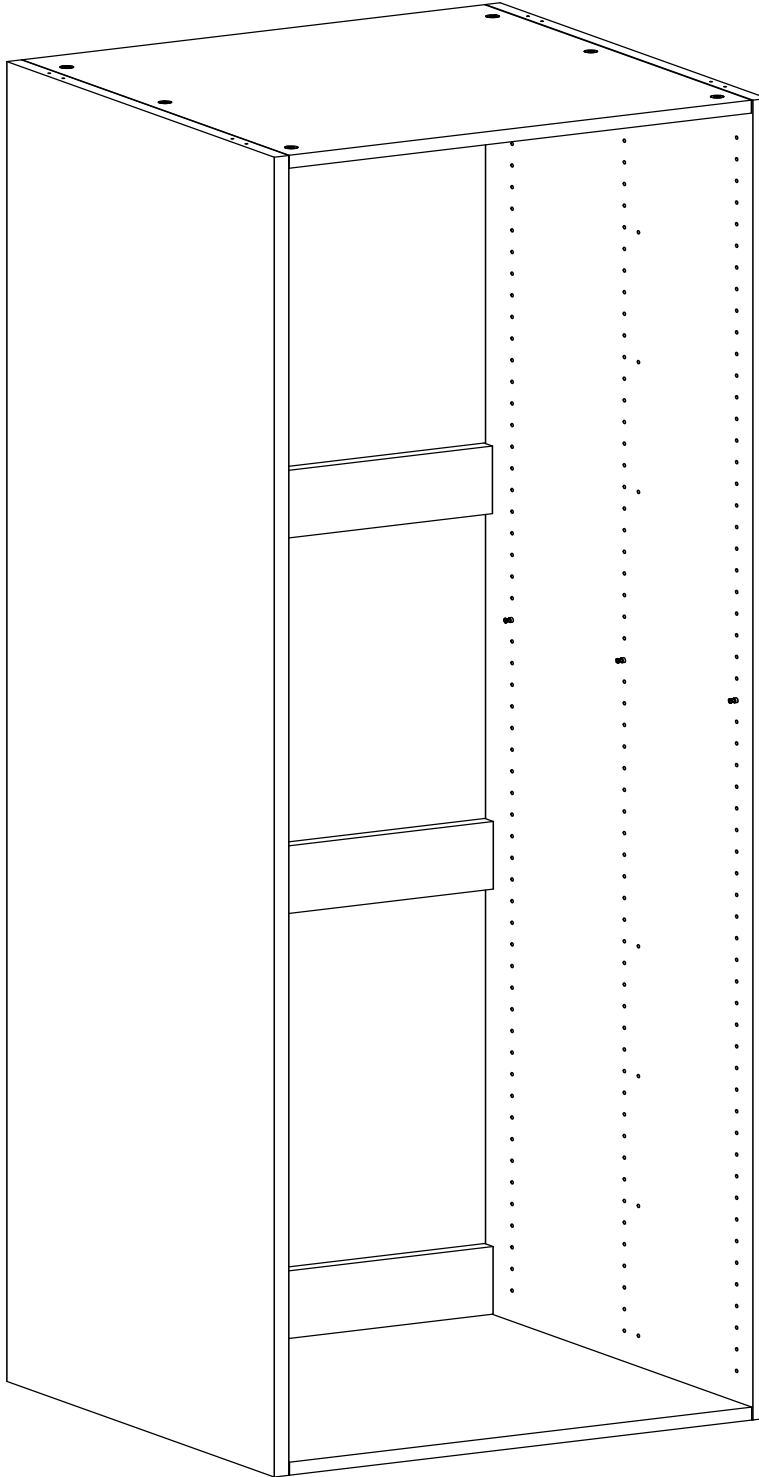
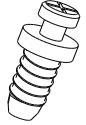



### Step 4

Insert shelf with wedgex clips facing downward into screw dowels.

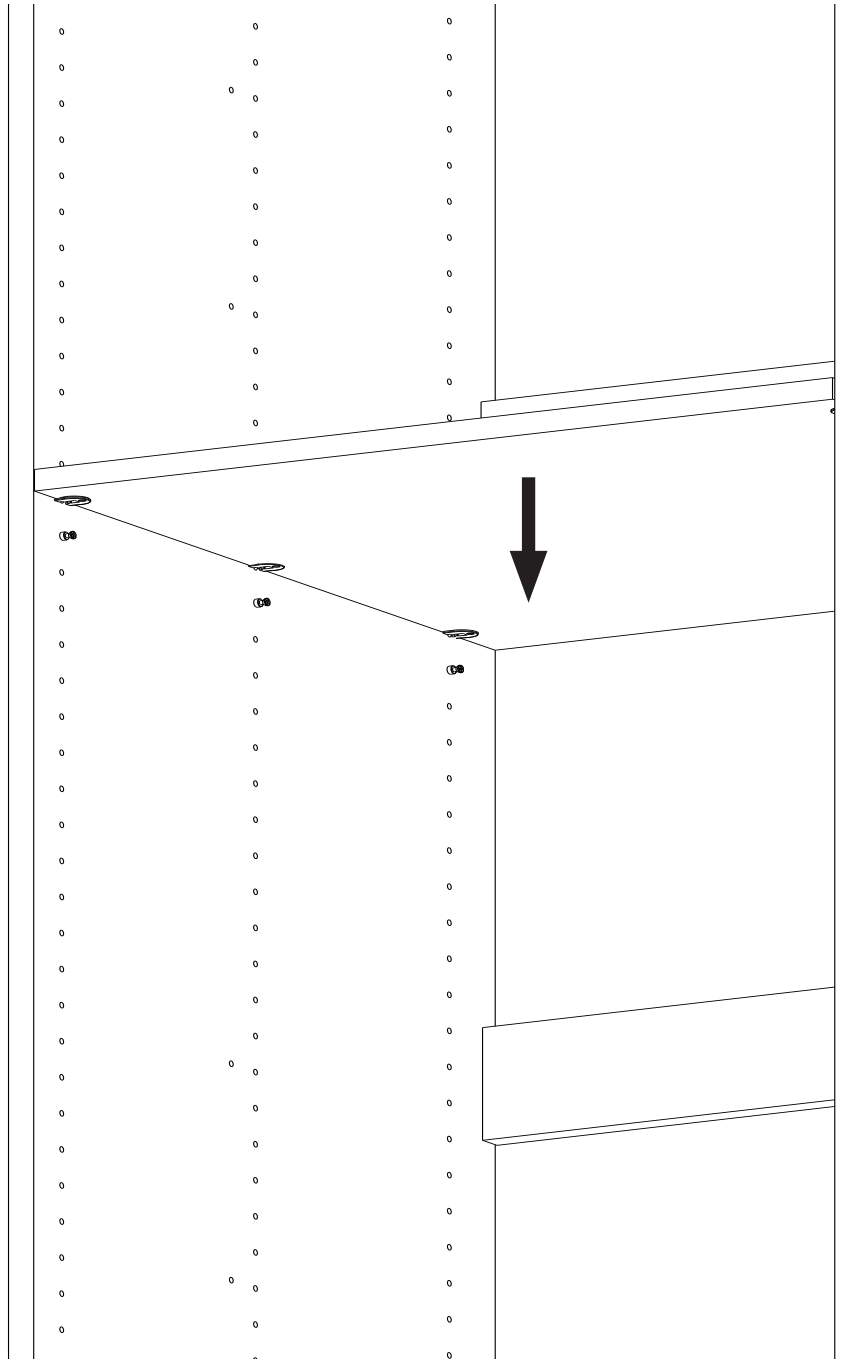



### Step 5

Ensure shelf is firmly pressed down and connected to screw dowels.

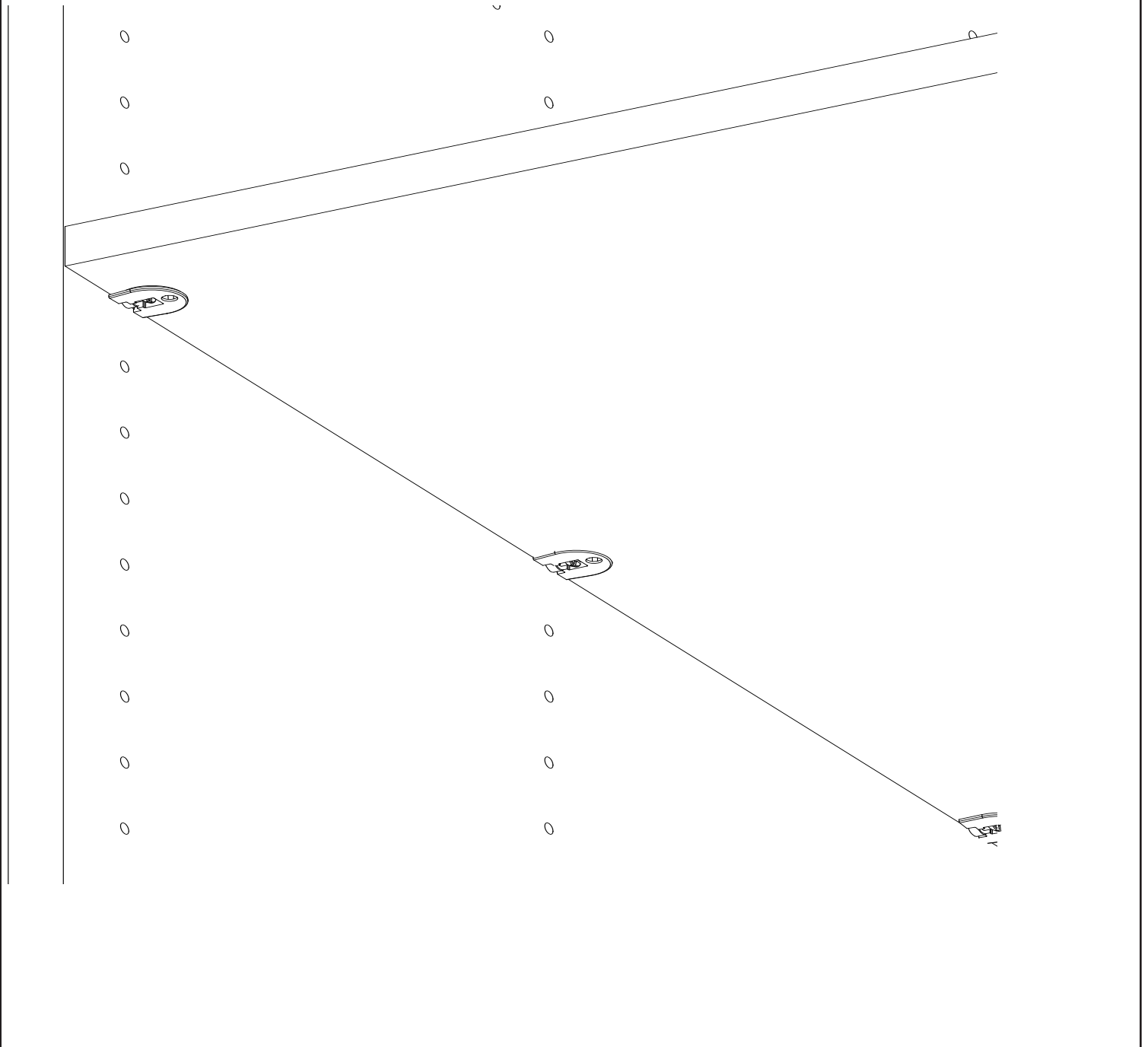



# Door Kits

## APPENDIX B

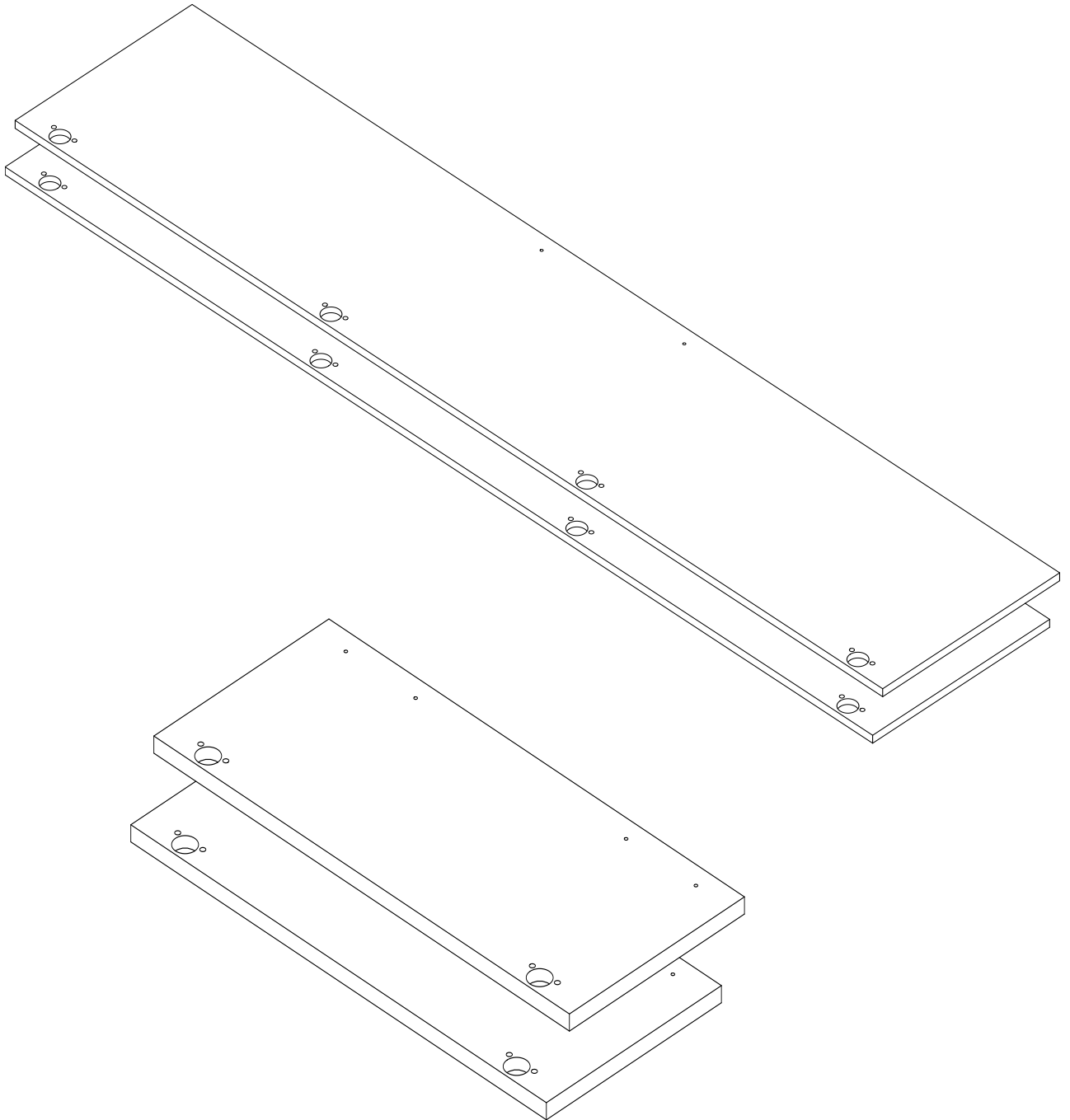

## Boxes Needed

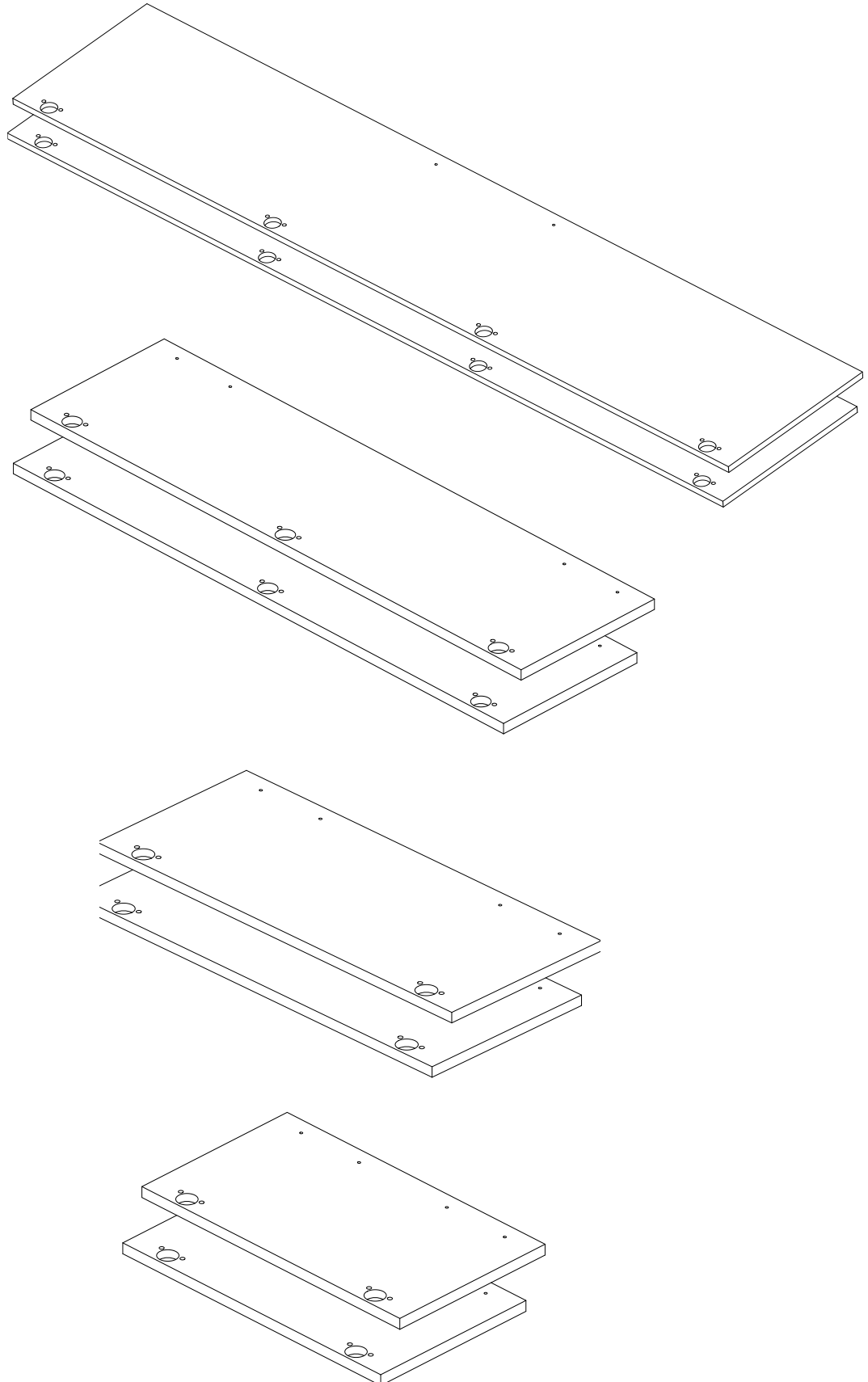

GRG-DO

Comes in heights at 23",  
30", 56", 76".



Hardware Packs Needed  
GRG-HRDP-DO

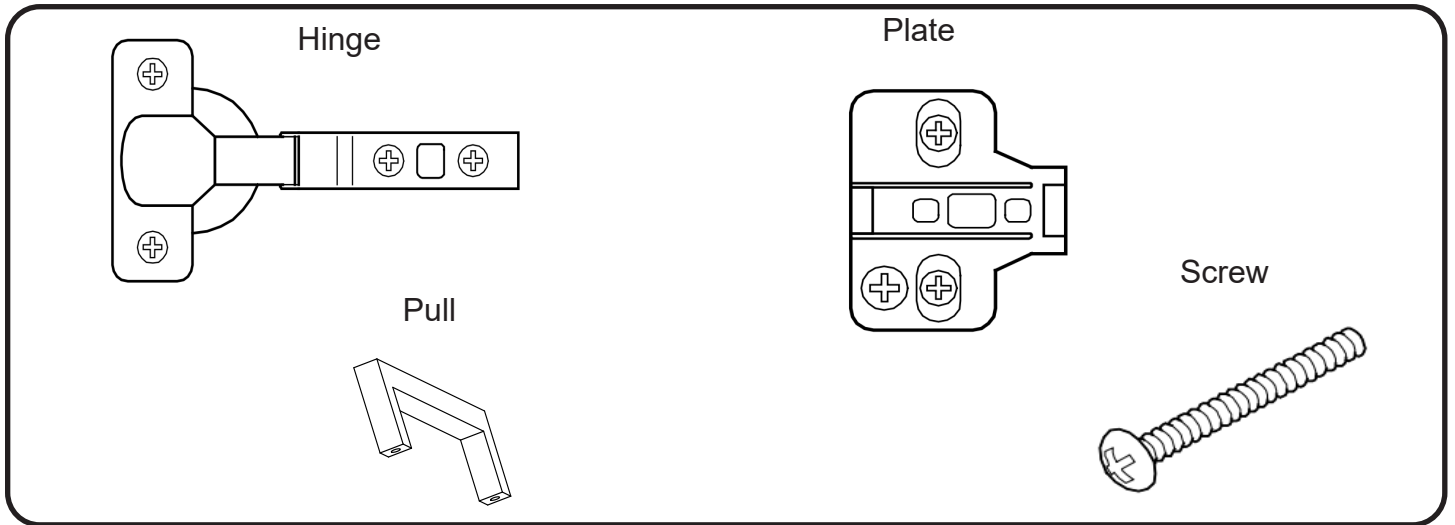

**Tools needed**

Rubber mallet



Drill

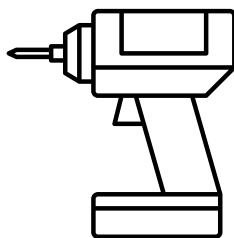

Level



Philips  
screw  
driver



Stud finder

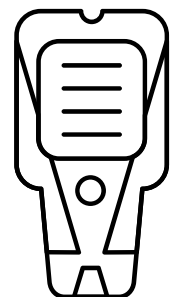

**2 person assembly suggested**

## Step 1

Take door hinges from hardware pack and insert them into all open slots in each door. With a screwdriver turn the screws to lock them into place.

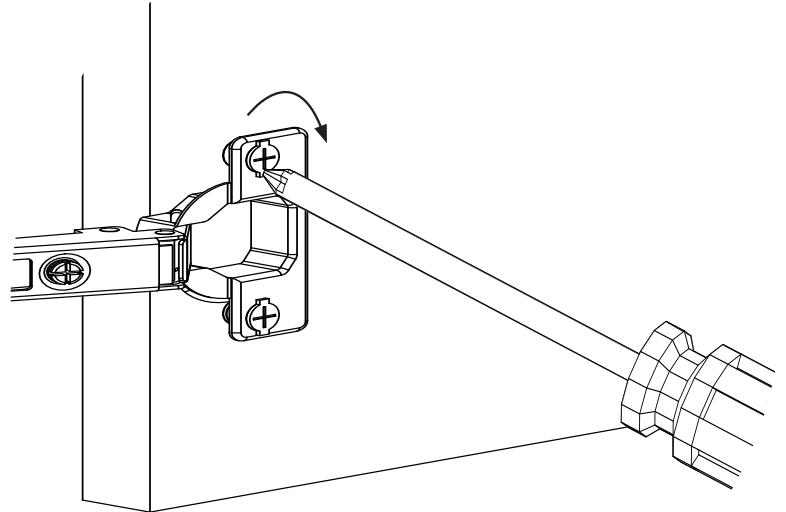
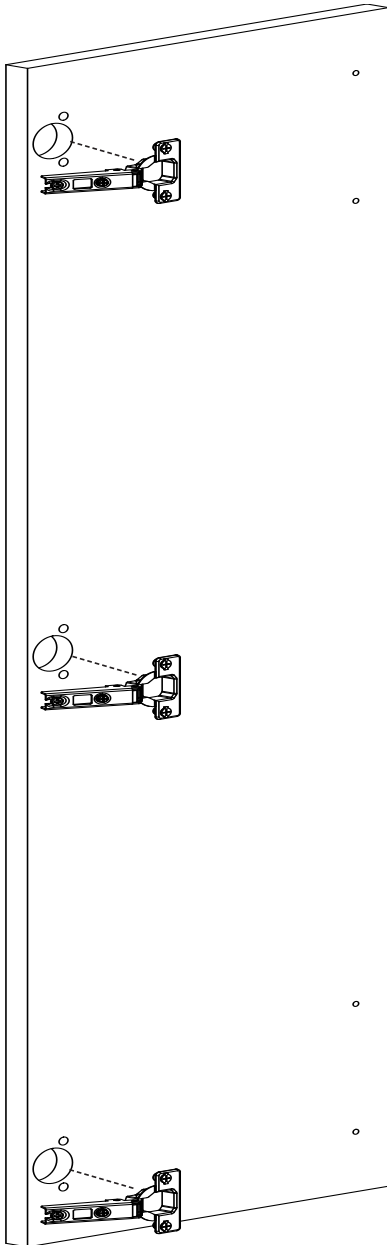



## Step 2

Use drill to punch supplied screws for handle attachment through the pilot holes on the door. Attach handle to screws on other side.

Drawer Pull

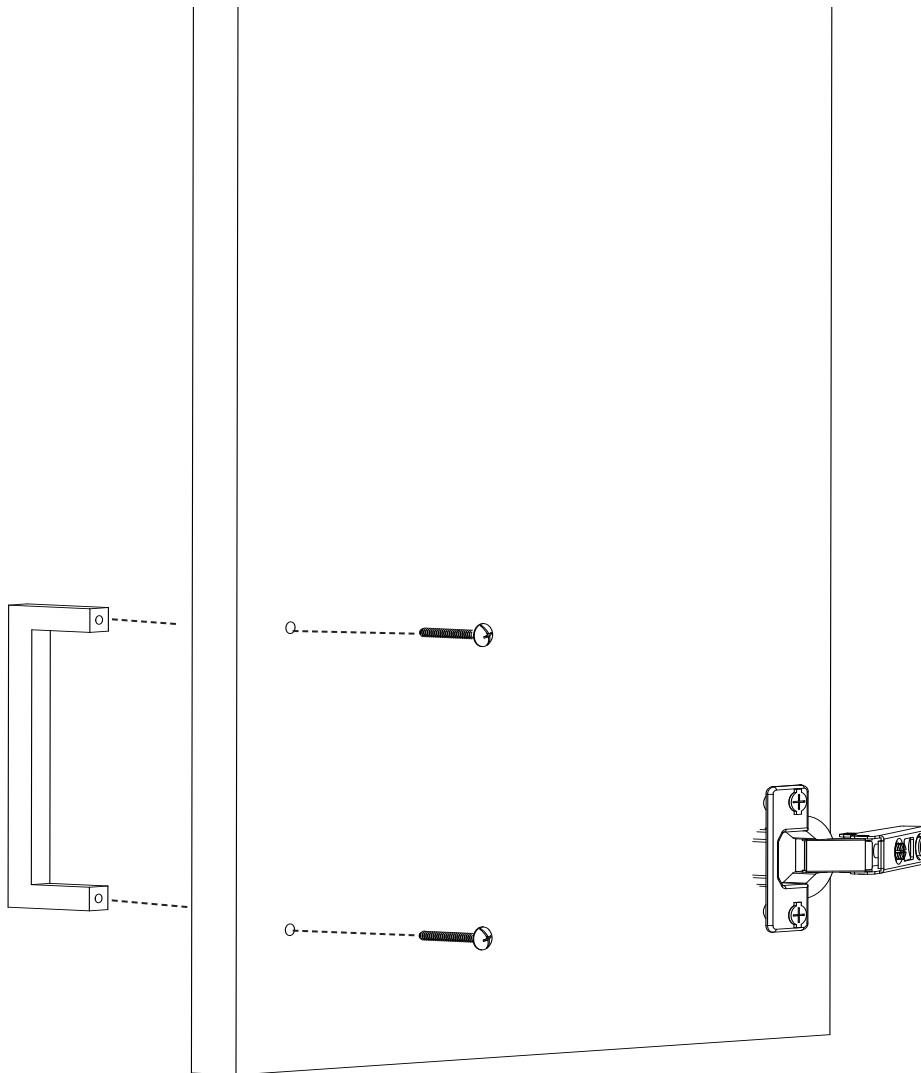
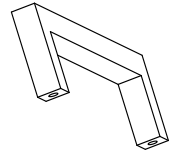

### Step 3

Insert and drill plates into one or both sides of the side panels to line up with installed door hinges.

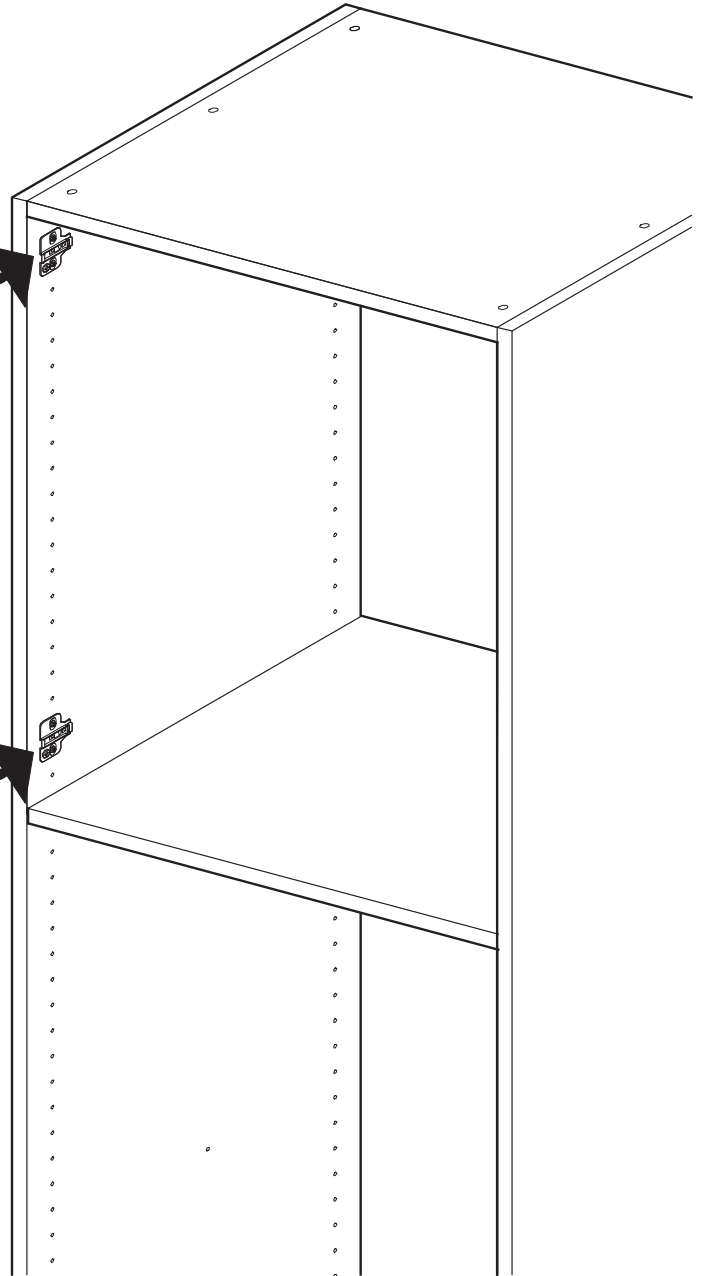
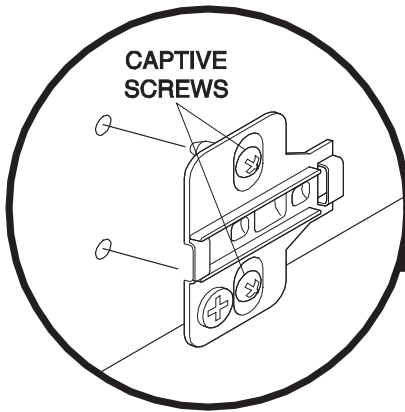
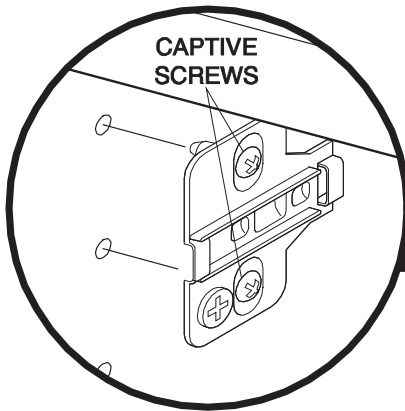



### Step 4

Insert hinges into plates installed. The door should click into place upon attachment.

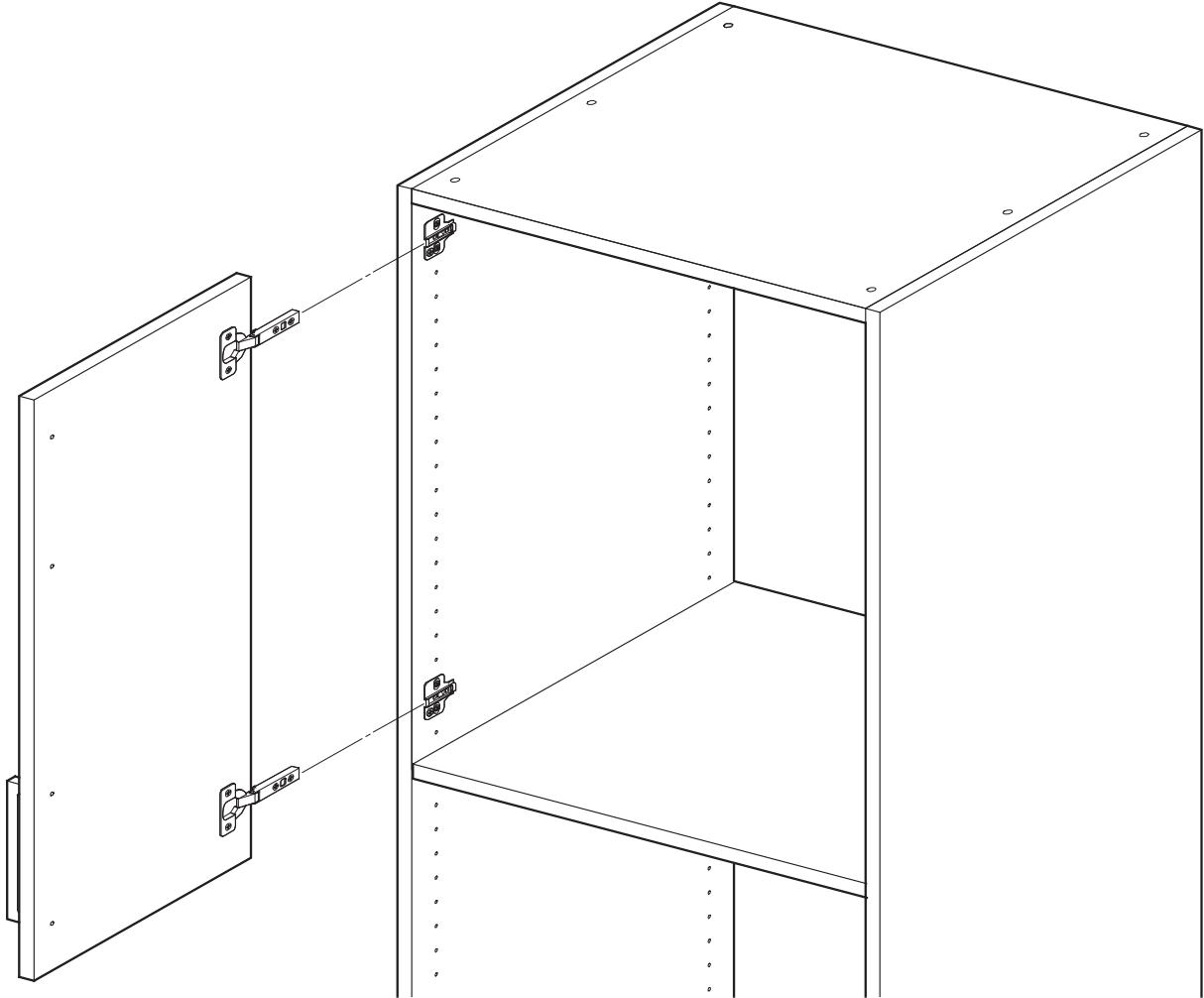

ADJUSTS POSITION OF HINGE  
IN OR OUT (DEPTH)

ADJUSTS POSITION OF  
HINGE SIDE TO SIDE

PRESS TO RELEASE HINGE  
FROM HINGE PLATE

ADJUSTS POSITION OF  
HINGE UP AND DOWN

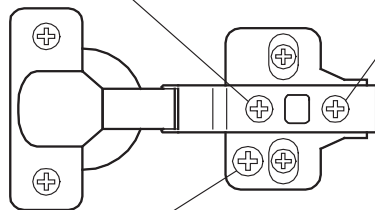



# Drawer Kits

## APPENDIX C

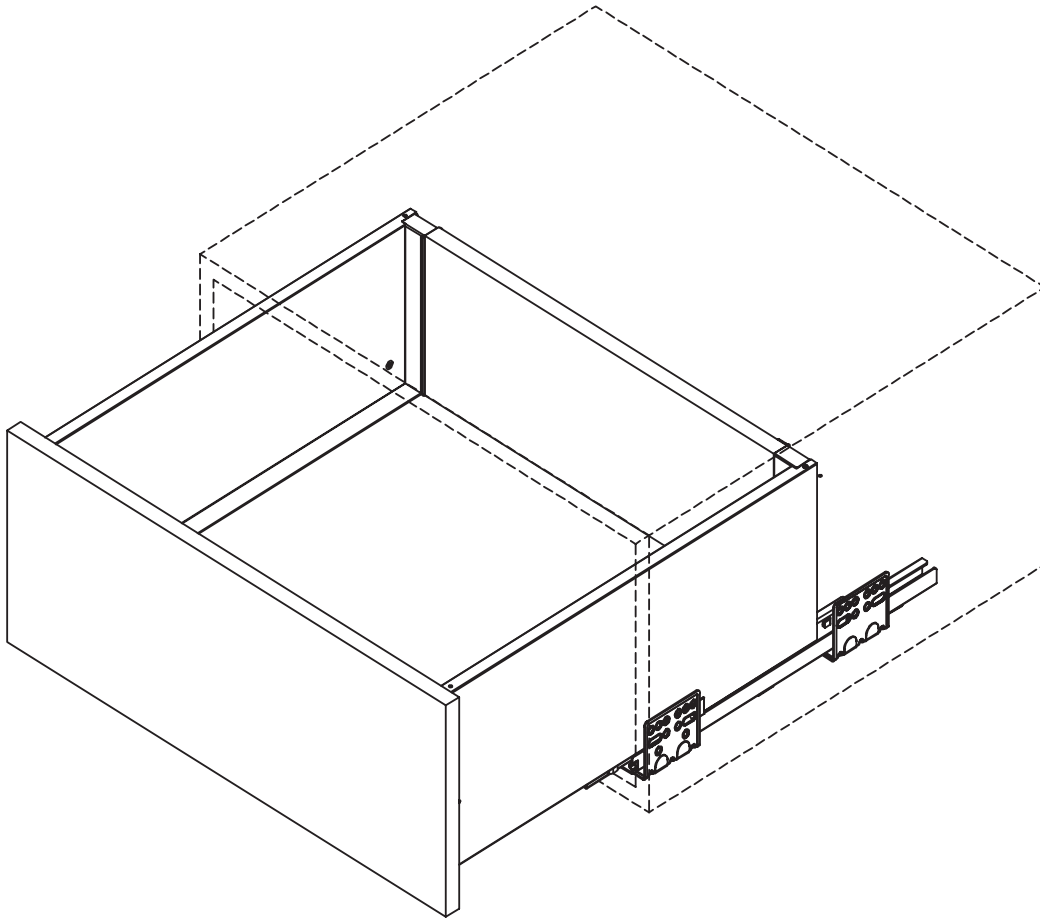



### Boxes Needed

GRG-DF  
(Large or Small)

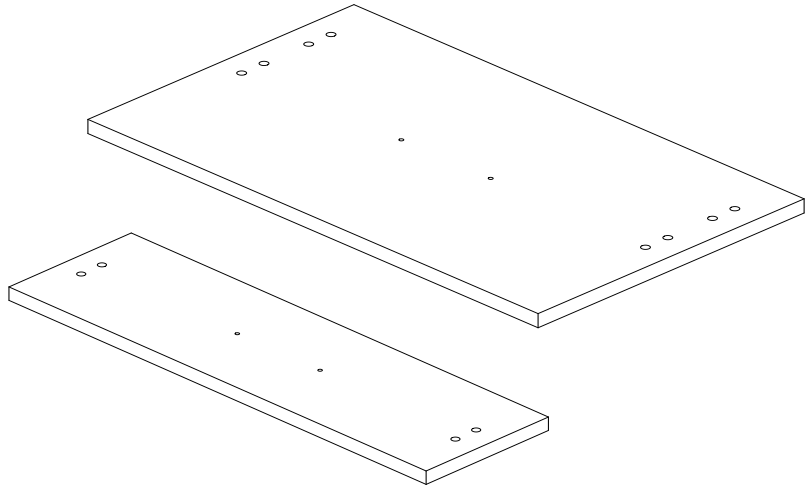

GRG-DB  
Base Fixed Shelf Pack

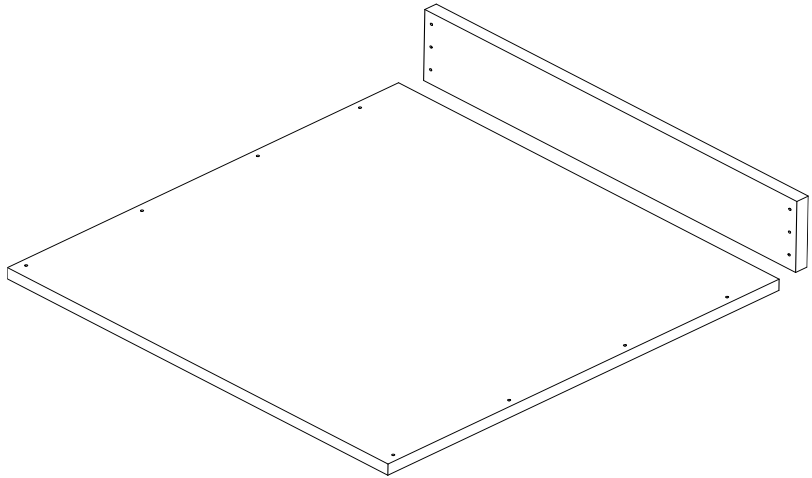

Hardware Packs Needed  
 GRG-HRDP-AXL  
 GRG-HRDP-DB(L/S)

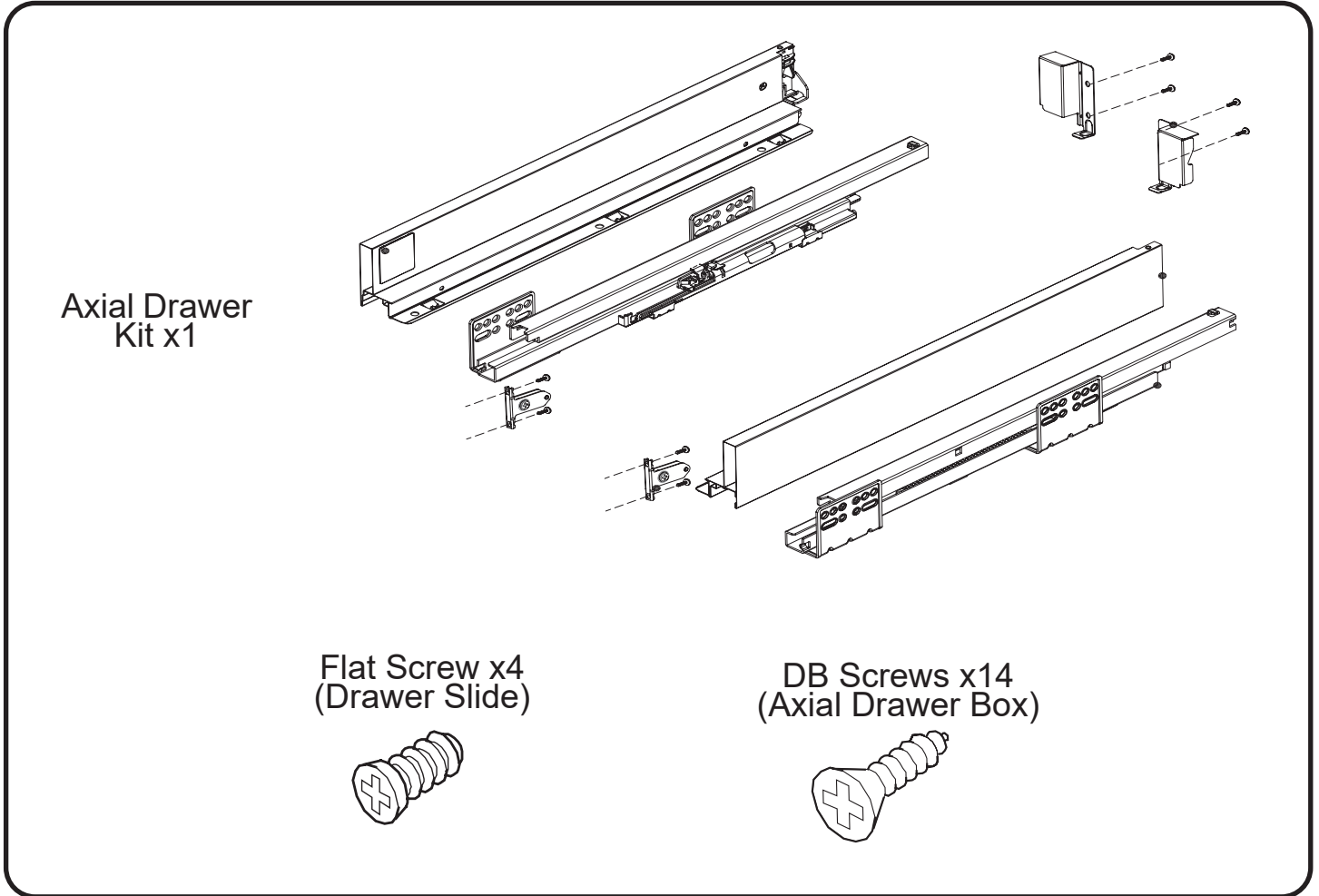

**Tools needed**

Rubber mallet



Drill

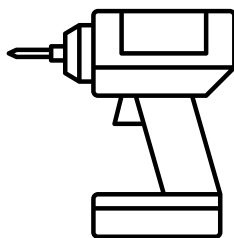

Level



Philips screw driver



Stud finder

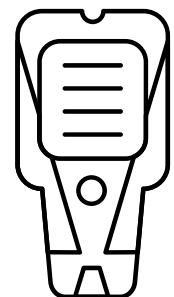

**2 person assembly suggested**



### Step 1

Install rear brackets to drawer sides.

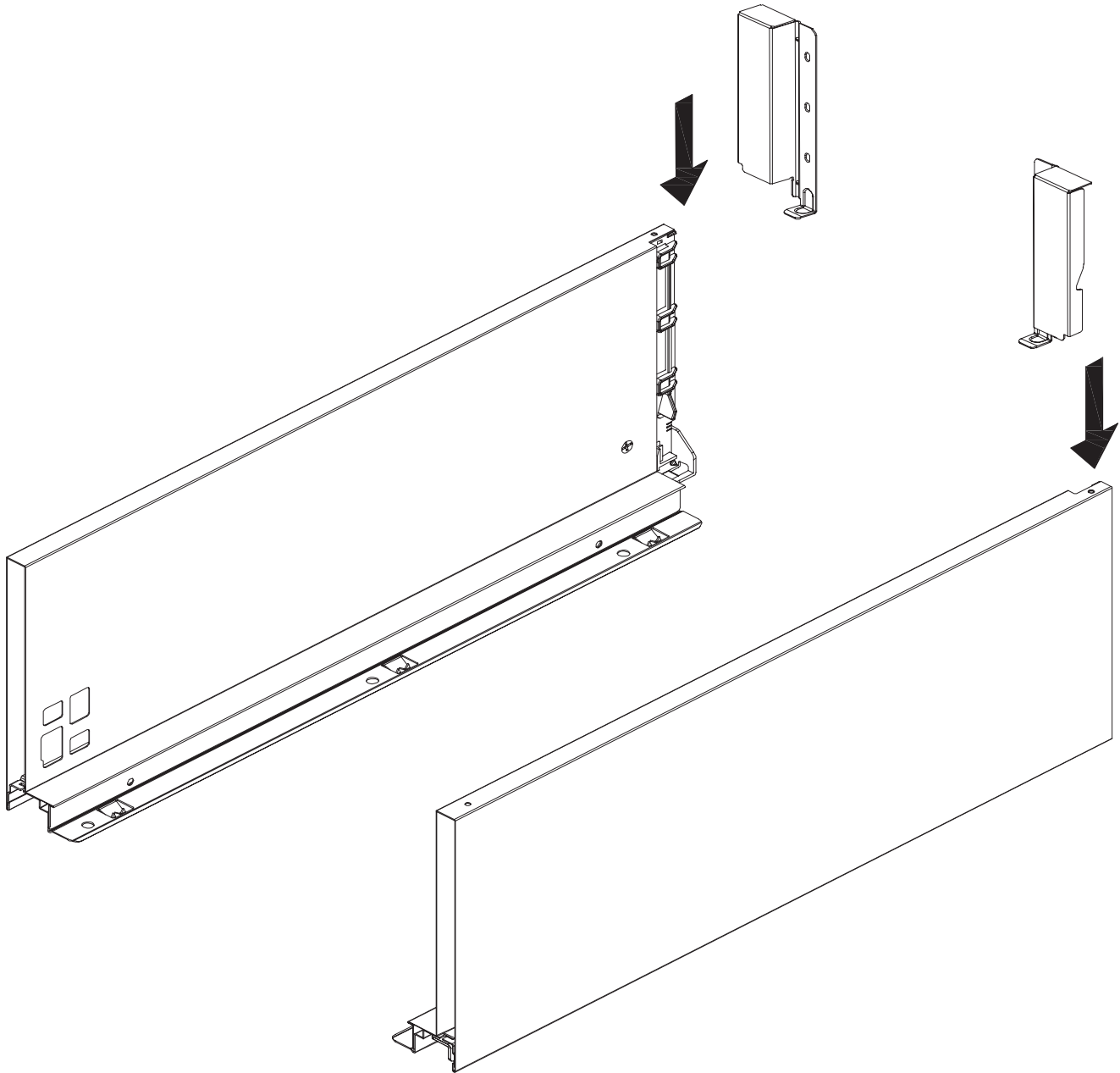

## Step 2

Mount drawer bottom with screws.

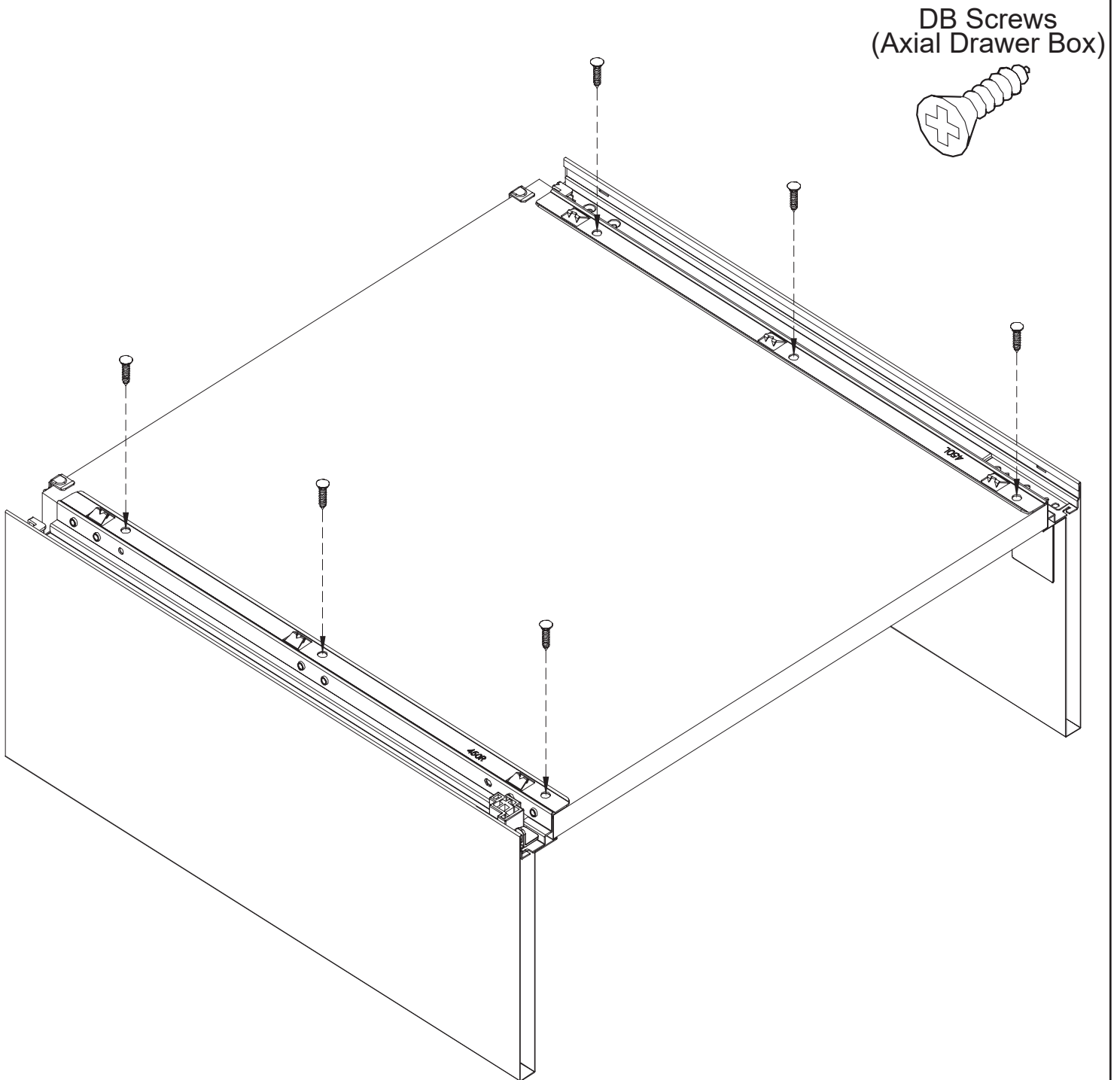



### Step 3

Mount drawer back to attached rear brackets. Secure with screws.

DB Screws  
(Axial Drawer Box)

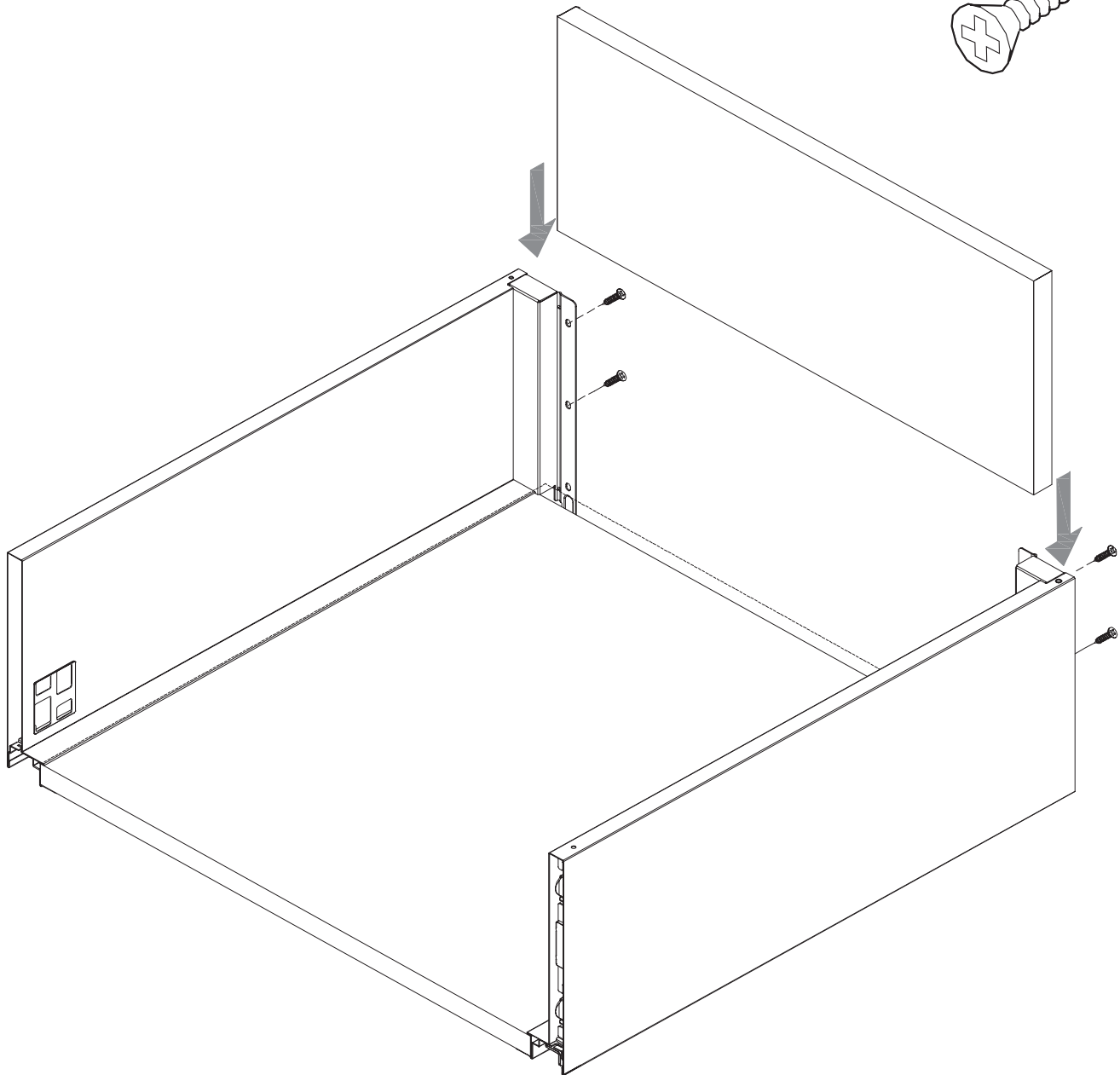
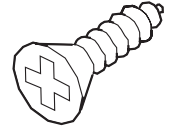

### Step 4

Mount front fixing brackets to drawer front pre drilled holes. Insert drawer front.

DB Screws  
(Axial Drawer Box)

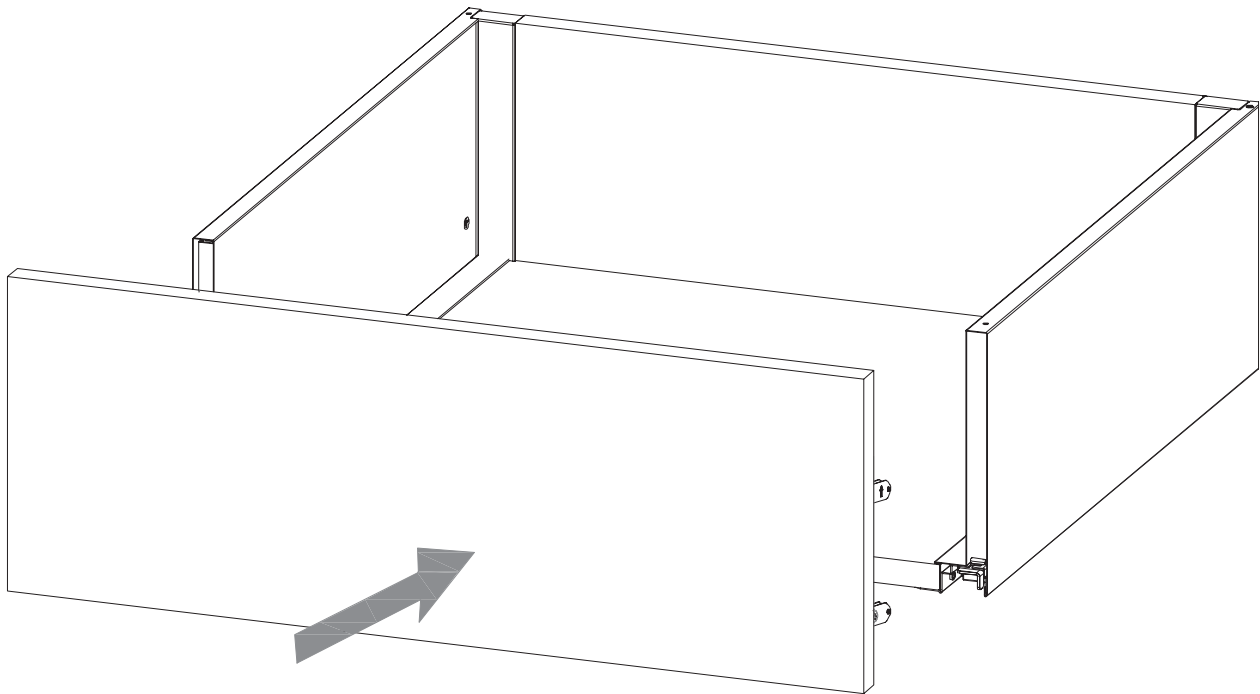
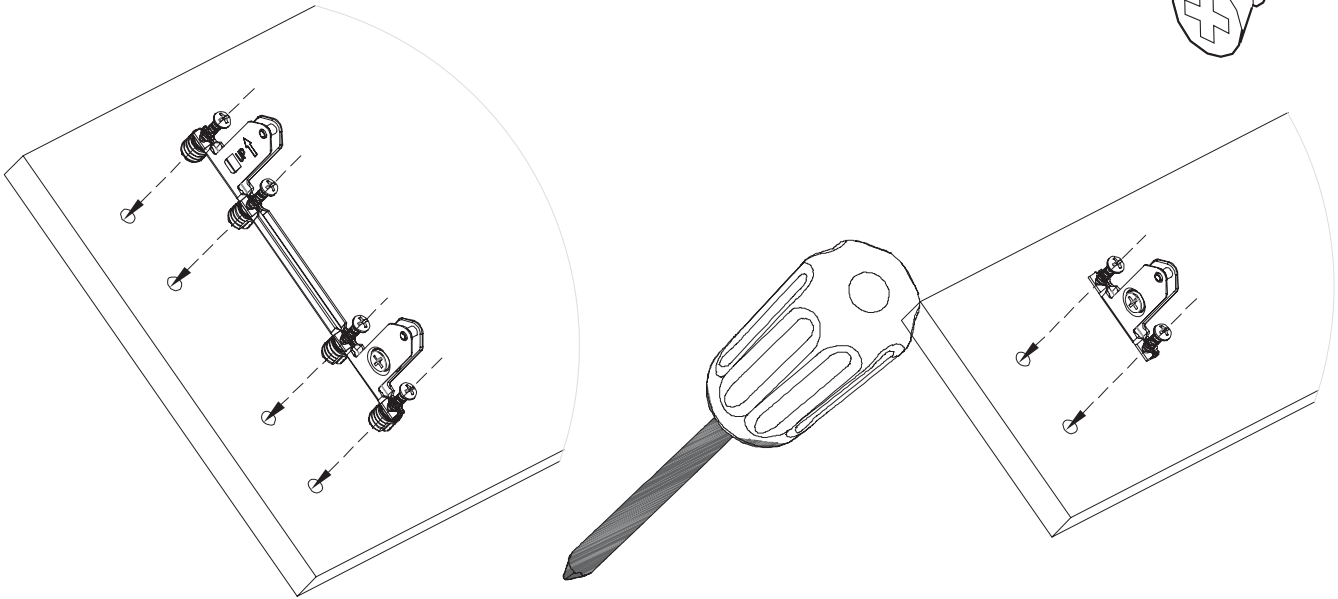
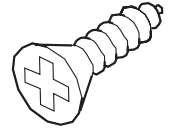



### Step 5

If using supplied handle, open GRG-HRDP-DF position screws and drill to punch them through the pilot holes on the drawer front and attach handle from other side.

Drawer Pull

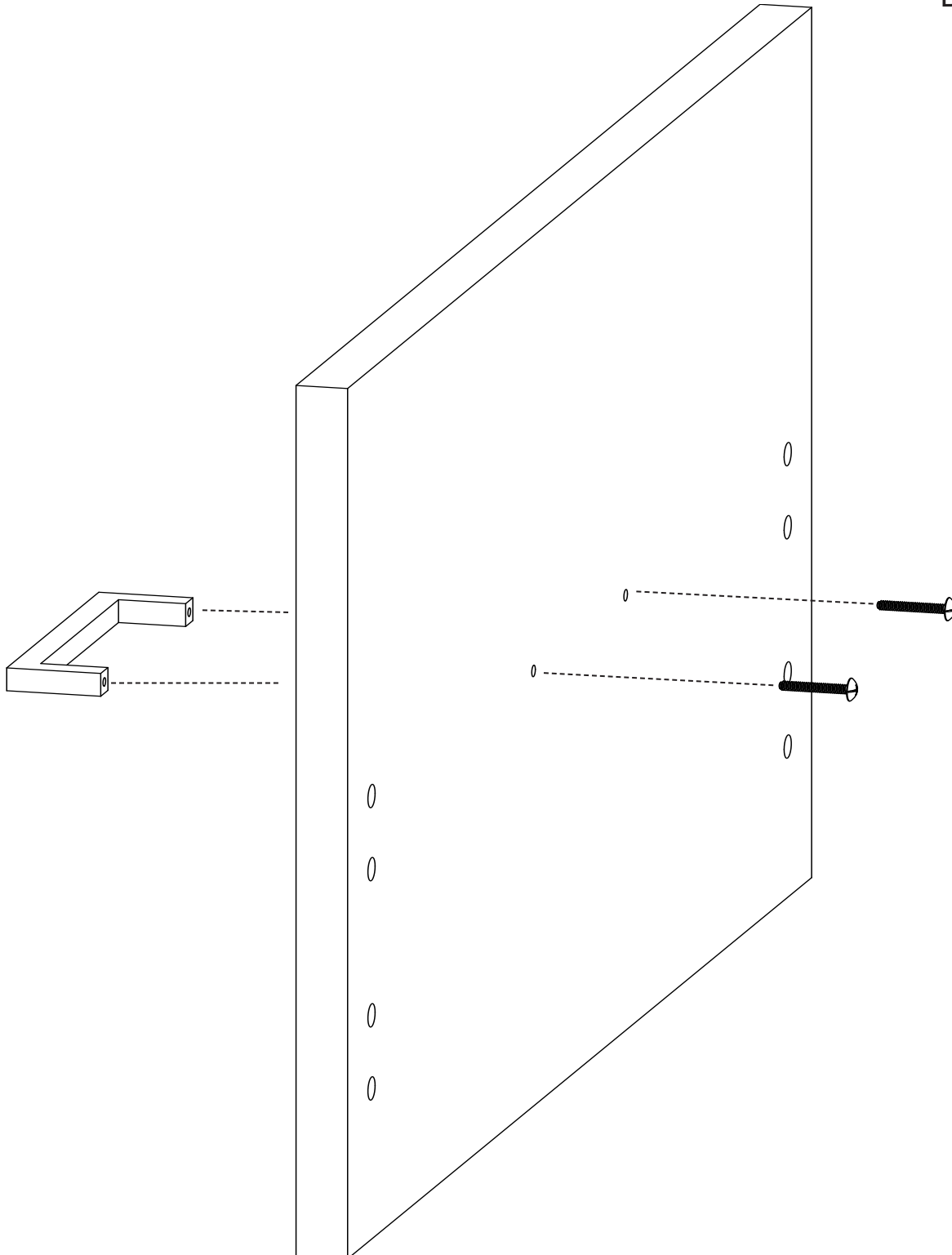
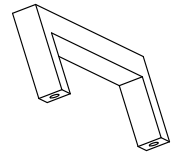



### Step 6

Install drawer slides to tall/base side panels using the diagram below to position your screw holes.

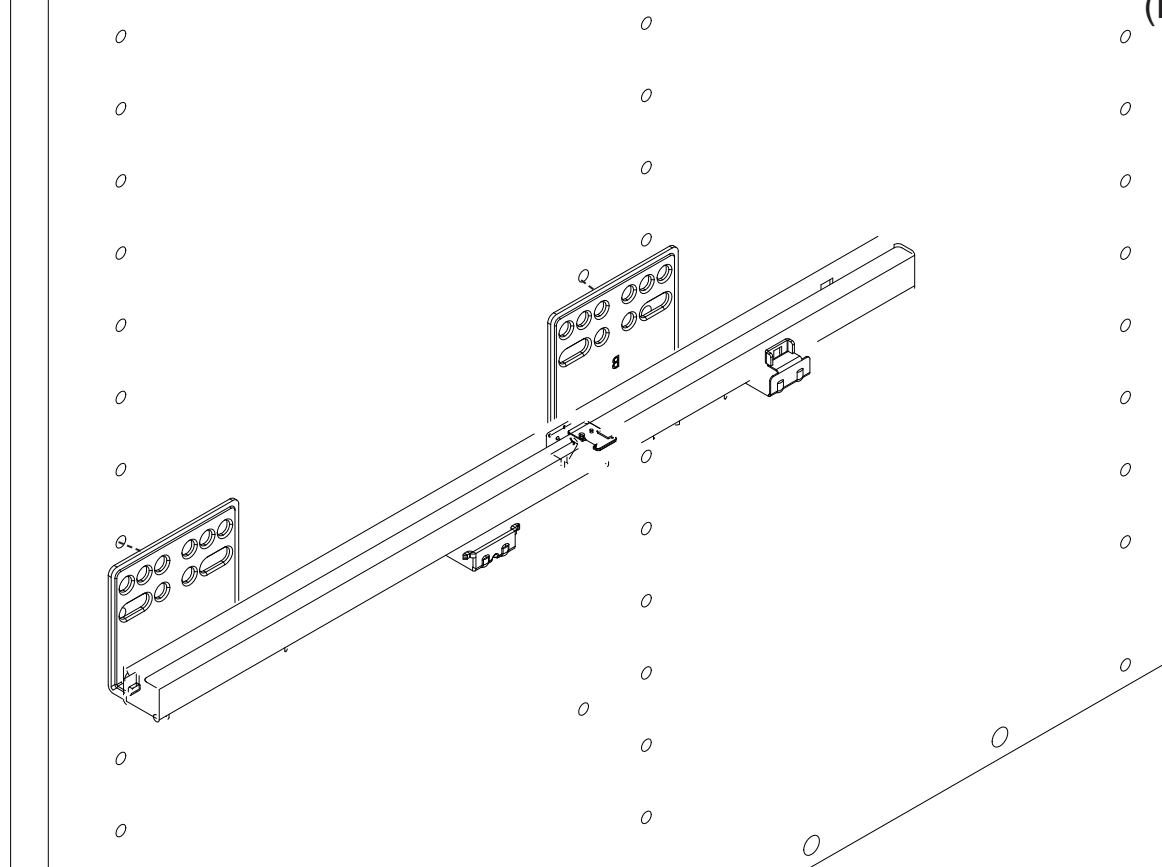

Flat Screw  
(Drawer Slide)

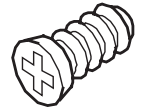

These two holes should  
have screws

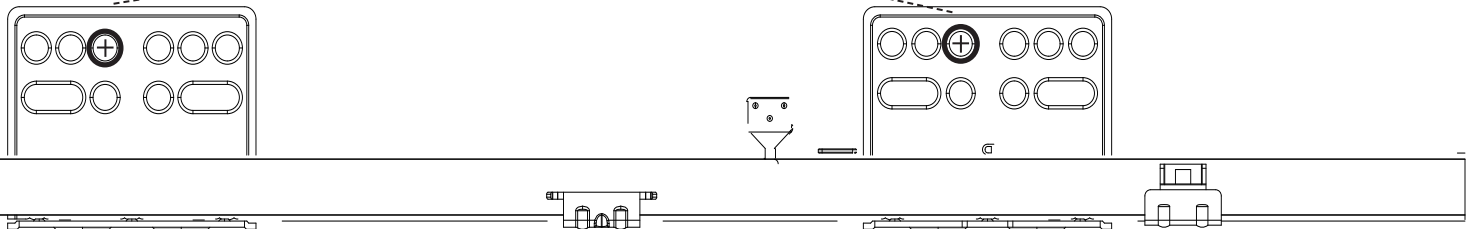



### Step 7

Insert drawer. Listen for a click to confirm it locked into slide. Repeat as necessary for all drawers.

